



2011

Sustainable Engineering Internship



David Bierman

Sara Coffey

Casey Hagg

Joel Kaatz

Executive Summary

Shoals Marine Laboratory (SML) is constantly searching for more sustainable engineering solutions. Recently, the addition of leech fields and composting toilets for human waste, solar thermal panels for heating water, and both a wind turbine and solar photovoltaic arrays for electricity generation have made the laboratory a model for sustainable island practice. SML began a Sustainable Engineering Internship (SEI) program in 2006 to give engineering students the opportunity to study the systems and give recommendations for further improvements. This year's SEI interns investigated alternative energy, diesel power generation, increasing the freshwater supply to the well, the fuel efficiency of the J.B. Heiser research vessel, solar thermal energy, composting toilets, Kiggins Commons acoustics, and the trash, recycling, and composting system on the island.

Alternative Energy

Though the Green Grid on Appledore Island is a good start towards sustainable electrical energy practice, SML is looking to expand this grid and continue to take loads off of the diesel generator. In order to give recommendations as to how SML might go about the expansion of the Green Grid, a further look at solar and wind energy sources was taken. A theoretical analysis showed that solar energy is a more practical decision for SML's search to provide more renewable energy during the summer.

Ultimately, there was not sufficient real-time data for the existing wind turbine or solar array output. This data would be the best way to understand how each system performs, and therefore to determine what is the best way to go about expansion. It is recommended to look further into data acquisition systems for monitoring electrical energy, including the equipment that is already in the Radar Tower. If it is determined that there is no way to obtain usable data from the existing programs, there are companies that provide monitoring systems which may prove to be more reliable than what is currently in place. These different options were explored.

Power Factor

Multiple power outages have motivated a study of SML's 27 kW diesel generator. It was found that the grid typically faces peak loads in the early afternoon and the late evening. At these times, the generator is most susceptible to a shut-down. Various electric motors on the island which rely on the generator for their power require very high currents to start running. These currents, when demanded from a strained generator, can cause the island's main electrical grid to go down.

The addition of capacitor banks to increase the usable capacity of the diesel generator was explored. Appropriate sizes for the capacitor bank would be 15 kVAR and it is recommended to split this reactive supply into three different banks which could be distributed around the grid. A harmonics analysis must be performed before these capacitor banks are installed.

Increase the Fresh Water Supply to the Well

In past seasons when the well has run low, SML has needed to run a reverse osmosis machine, which turns sea water into fresh water at an alarmingly inefficient rate. In order to mitigate the usage of this machine, other freshwater sources were investigated. Currently, a permit exists which allows the staff to drain a fixed amount of water from Crystal Lake (the next most easily accessible freshwater source on the island).

Without filtration, Crystal Lake water is not potable. Slow sand filtration techniques, which are gravity driven, were investigated to determine whether or not they would be a feasible solution. Two sand filters were created and the effluent turbidity was monitored over the course of a few weeks. A fine, 0.42 mm sand showed quick effectiveness, eventually removing nearly 90% of the turbidity of Crystal Lake, as well as a significant amount of *E. Coli* pathogens.

Designs for a full size slow sand filter were developed, which introduced a wide variety of factors and concerns. These results should be further investigated in order to decide on the most practical system for Appledore Island.

Additionally, the depth profile of Crystal Lake was studied, and it was determined that the total volume of water is over 60,000 ft³, which is nearly 40% larger than the previous estimate.

John B. Heiser Research Vessel Performance

The J.B. Heiser Research Vessel's original engine was replaced this past winter. Engine performance was monitored in order to determine optimum operating conditions. It was determined that at light loads, running the boat between 2300 and 2600 RPM gave the greatest fuel efficiency. At higher RPM levels, fuel efficiency begins to decrease. At heavy loads, the engine's RPM level was not observed to have a significant effect on the fuel efficiency within the measured range.

Ultimately, it is recommended to collect further data to gain a better understanding of the boat performance. This can be accomplished either by a continuation of the data collection method developed by this year's SEI interns, or through a digital monitoring system provided by Caterpillar. It is not clear how much SML would gain from this expensive system, however.

Shoals Sustainable System Awareness

The Water Conservation Building was constructed in Fall 2010, and with the 2011 season came the addition of composting toilets and a solar thermal system for heating freshwater. By developing graphics which explain the basic functionality of these two systems, a deeper understanding of sustainable practice amongst the visitors and staff of Appledore Island is sought. These graphics will be displayed in the Kiggins Commons dining hall and at the entrance to the Water Conservation Building.

Kiggins Commons Acoustics Improvement

The 2010 SEI interns worked to quantify the undesirable acoustical characteristics of Kiggins Commons. In May of 2010 at Volunteer's Weekend at SML, 60 acoustic panels were installed. Since then, the sound performance has been characterized by an overwhelming qualitative approval. It was determined that the reverberation time (a measure of echo in the room) was decreased by approximately 70% at high frequencies. It was also determined that the improved reverberation times in the room fall in the recommended range as defined by last year's interns. It is recommended to not seek further acoustical improvements, as the cost to move forward would outweigh the acoustic benefits.

Trash, Recycling, and Composting Shed for Temporary Storage

Though the current trash, recycling, and composting system on Appledore Island is functional, there are a few aspects which make it unfavorable. Some of these include the unappealing aesthetic appearance of the shed, its central location (which, in conjunction with the first reason makes it an "eyesore" to the population), as well as the shed's prohibitive volume.

Taking these factors into consideration, a new shed was designed which would be located on the other side of Kiggins Commons. This walk-in shed is more accessible and has a larger volume which is more appropriately sized for the trash, recycling, and compost system.

Table of Contents

Introduction	4
Alternative Energy	5
Background	5
Objectives	5
Theory	5
<i>Solar Photovoltaic Panels</i>	5
<i>Wind Turbine</i>	6
Procedure.....	7
<i>Solar Photovoltaic Panels – Theoretical Output</i>	7
<i>Wind Turbine – Theoretical Output</i>	8
Results and Analysis.....	8
<i>Energy Output</i>	8
<i>Monitoring and Data Logging System</i>	11
Recommendations	14
Diesel Generator and System Power Factor	16
Background	16
Objectives	16
Theory	16
Procedure.....	17
Results and Analysis.....	18
<i>Energy Consumption</i>	18
<i>Generator Shut Down</i>	19
<i>Low Power Factor</i>	27
Recommendations	29
Increase Fresh Water Supply to the Well	35
Background	35
Objectives	35
Theory	35
Procedure.....	36

Results and Analysis.....	38
<i>Testing and Data Collection</i>	38
<i>Filter Problems</i>	40
<i>Mapping Crystal Lake</i>	41
Recommendations	42
<i>Filter Design Solutions</i>	42
<i>General Design Concepts</i>	43
<i>Proposed Filter Design</i>	48
<i>System Design Solutions</i>	49
<i>Additional Options</i>	53
John B. Heiser Research Vessel Performance Measurements	54
Background	54
Objectives	54
Procedure.....	54
Results and Analysis.....	55
<i>Light Loads</i>	56
<i>Heavy Loads</i>	57
Recommendations	57
Shoals Sustainable System Awareness	59
Background	59
Objectives	59
Procedure.....	59
<i>Composting Toilets</i>	59
<i>Solar Water Heating System</i>	59
<i>The Green Grid</i>	59
Results and Analysis.....	59
<i>Composting Toilets</i>	60
<i>Solar Water Heating System</i>	61
<i>The Green Grid</i>	62
Recommendations	63

Kiggins Commons Acoustic Improvements	64
Background	64
Objectives	64
Theory	64
Procedure.....	66
Results and Analysis.....	69
Recommendations	73
Trash, Recycling, and Composting Shed for Temporary Storage	74
Background	74
Objectives	74
Procedure.....	74
Results and Analysis.....	76
Recommendations	79
Acknowledgements	81
Future Project Suggestions	82

Introduction

Shoals Marine Laboratory is constantly searching for more sustainable engineering solutions. Recently, the addition of leech fields and composting toilets for human waste, solar thermal panels for heating water, and both a wind turbine and solar photovoltaic arrays for electricity generation has made the laboratory a model for sustainable island practice. Shoals Marine Laboratory began a Sustainable Engineering Internship (SEI) program in 2006 to give engineering students the opportunity to study the systems, and give recommendations for further improvements. This year's SEI interns investigated alternative energy, diesel power generation, increasing the freshwater supply to the well, the J.B. Heiser Research vessel, solar thermal energy, composting toilets, Kiggin's Commons acoustics, and the trash, recycling, and composting system on the island.

Alternative Energy

Background

Shoals Marine Lab of Appledore Island has a prestigious reputation for sustainability due in part to its conservative inhabitants as well as its innovative ones. In the past three years, Shoals has installed 7.5kW of photovoltaic (PV) panels and a 7.5 kW wind turbine. Though the island runs primarily on a diesel generator, Shoals alternative energy 'green grid' supplies power to the radar tower, AIRMAP's meteorological devices, and Dorms 2 and 3. In order to further reduce the island's dependence on diesel energy generation, Shoals is attempting to expand the green grid. Since Appledore Island has unique needs, the method of alternative energy generation which would facilitate an effective and efficient expansion must be determined.

Objective

Determine the most effective form of alternative energy generation to expand the green grid. Make recommendations on how to collect, store, and display the output of the 7.5kW Bergey wind turbine and the 7.5 kW solar array on Appledore Island.

Theory

Solar Photovoltaic Panels

Using a series of formulas, the energy output of the solar photovoltaic panels can be calculated. The equations used for this analysis are outlined below. All degree values should be in radians.

As sunlight travels through the earth's atmosphere it encounters obstacles, such as clouds, which cause it to scatter. This results in a varying light intensity reaching the earth's surface. The ratio of the monthly average diffuse radiation to the monthly average total radiation can be calculated with the equation below.

$$\frac{H_d}{H} = 1.39 - 4.03(K_t) + 5.53(K_t)^2 - 3.11(K_t)^3 \quad (1.1)$$

Where:

K_t represents the ratio of actual daily radiation on a horizontal surface to the daily extraterrestrial radiation on a horizontal surface

The intensity of the sunlight varies based on the tilt of the surface as well. The ratio of average total radiation on a tilted surface for a month to the corresponding average radiation on a horizontal surface, \bar{R} , can be calculated:

$$\bar{R} = \left(1 - \frac{\bar{H}_d}{H}\right) \bar{R}_b + \left(\frac{\bar{H}_d}{H}\right) \frac{(1 + \cos S)}{2} + \frac{\rho(1 - \cos S)}{2} \quad (1.2)$$

Where:

R_b represents the ratio of average direct beam radiation on a tilted surface for that month to corresponding average direct beam radiation on a horizontal surface

S represents surface tilt angle

ρ represents the reflectivity of the environmental surface

Using the values found above, the average daily radiation on the tilted surface, H_T ($Btu/day \cdot ft^2$), can be found:

$$\bar{H}_t = \bar{H} \cdot \bar{R} \quad (1.3)$$

Where:

\bar{H} Represents monthly average of actual daily solar radiation on a horizontal surface ($Btu/day \cdot ft^2$)

The energy generated by a solar panel can then be calculated using the above values and the following equation.

$$E = \bar{H}_t \cdot \eta \cdot A \cdot t \cdot n \quad (1.4)$$

Where:

η represents array efficiency

A represents panel array area (m^2)

t represents hours per day of energy generation

n represents the number of days in the month

E represents energy generated (kWh/month)

Wind Turbine

From the observed wind speed over the span of a year, a histogram of wind speeds can be made. From this the probability of seeing a wind speed at any point can be calculated. Using the equations below, a theoretical energy output can be calculated.

Observed wind speeds vary depending on the height. Generally, the higher the elevation, the faster the wind speeds. However, with knowledge of some properties of the surrounding air and weather conditions, it is possible to calculate the wind speed at a different elevation from where the speeds were originally measured.

$$V_{wind\ turbine} = V_{radio\ tower} \cdot \left(\frac{H_{wind\ turbine}}{H_{radio\ tower}}\right)^\mu \quad (1.5)$$

Where

μ is a unitless wind shear parameter. To simulate open waters a value of $\mu=0.11$ was used.

V represents the velocity (*ft/s*)

H represents the height (*ft*)

Based on power output values found experimentally, the manufacturer of the turbine lists theoretical power output values for a range of wind speed bins. Multiplying the power output of a particular speed by the probability of seeing that wind speed gives the energy output for a particular wind speed bin.

$$\text{Energy} \left(\frac{\text{kWh}}{\text{day}} \right) = \text{Power}(\text{kW}) \cdot \text{Wind Speed Probability} \quad (1.6)$$

Procedure

Since Shoals Marine Lab operates primarily during the summer, only data on solar and wind production from May through September will be considered for this analysis. Classes are run from May through August, though staff members arrive on Appledore Island in late April and remain through September.

Theoretical energy outputs of the solar panels and the wind turbine will be calculated for this time period. By comparing these two outputs, the more practical renewable energy source for SML will be determined. This analysis is also based on economics, carbon emissions and compatibility with SML's current electrical system.

Solar Photovoltaic Panels – Theoretical Output

Data was collected in order to calculate the theoretical output of the PV panels. This theoretical value predicts the amount of energy the PV panels can potentially produce. Data collected included monthly solar irradiance values averaged over 30 years from Portland, ME provided by the National Renewable Energy Laboratory website. Additionally, energy output (kWh) of the current solar arrays can be estimated. Values for K_t were retrieved from the National Renewable Energy Laboratory's website. Data for Portland, ME was used since it was the closest city with similar conditions to those observed on Appledore Island.

All values were input into an excel spreadsheet. Using theoretical equations, including equations 1.1 through 1.4, the energy output was calculated. The spread sheet can also be used to investigate various factors which deal with the solar panel's production, such as the effect of the surface tilt angle on power output.

Wind Turbine – Theoretical Output

Data was collected from the AIRMAPs database on observed average daily wind speeds. These values were recorded from the top of the radio tower, 172 ft above sea level. From this data wind speed bins were selected and a histogram was made to determine the probability of observing each wind speed bin. Using equation 1.5, a theoretical energy output can be calculated to simulate open waters. A value of $\mu=0.11$ was used.

Using equation 1.6, the energy outputs at particular wind speeds were calculated.

Summing these energy values for all observed wind speeds, the total energy output was calculated.

Results and Analysis

Energy Output

Below we can see the theoretical energy production of both solar and wind power.

Table 1.1: Theoretical values for energy production per season

Theoretical Output	kWh (May-Sept)
Solar	5099
Wind	3537

Table 1.1 shows that during the months of May through September, based on theoretical calculations, PV panels can generate a greater amount of energy compared to the wind turbine. This makes sense since this time of year observes the highest insolation values and the lowest wind speeds. Therefore, solar photovoltaics are more effective as an energy generator than the wind turbine during the summer season.

A comparison of the amount of CO_2 emissions produced by each source is seen below in **Table 1.2**.

Table 1.2: Pounds of CO₂ emissions avoided by using the theoretical energy generated from the green grid.
(www.epa.gov/oms/climate)

	7.5 kW PV Array	7.5 kW Wind Turbine
Gallons of Diesel Saved	28.6	19.9
CO ₂ emissions/gallon of Diesel (lbs)	22.2	22.2
CO ₂ Saved (lbs)	637.1	442.0

This analysis shows that the PV panels can save more CO₂ emissions than the wind turbine.

Finally, the cost of each system is seen in **Table 1.3 below**.

Table 1.3: Average cost of solar and wind energy generation.

	Expected Life (yrs)	Total Costs (\$)	\$/kWh
Solar Panels	20	70,722	0.69
Wind Turbine	30	100,000	0.94

These values are based on the amount of energy generated daily, the expected lifetime of the mechanism, and the total initial costs of the mechanism. Since the wind turbine theoretically generates less energy from May through September and costs more than the PV panels, it has a higher overall energy cost despite its longer expected lifetime. This is further evidence that PV energy generation is more effective for SML compared to wind energy generation.

A simple payback period analysis is another method of determining which alternative energy option is a better investment. A simple payback period is the period of time required for the return on an investment to repay the sum of the original investment. In our case, the money saved by solar or wind energy generation will be calculated in comparison to costs avoided by diesel energy generation. A calculation using the diesel fuel logs on the island estimated the cost per kWh of diesel fuel as \$0.54. This value was used in the simple payback period analysis.

Table 1.4: Simple payback period of the PV panels and wind turbine (ignoring inflation).

	PV Panels	Wind Turbine
Total Initial Cost	\$70,722	\$100,000
kWh Gained (May-Sept)	5099	3537
Money Saved Per Year	\$2,753	\$1,535
Simple Payback Period (yrs)	26	65

The simple payback periods represented here are based on the assumption that all the energy generated by the PV panels and the wind turbine is utilized and, in turn, diverts the use of diesel energy. As seen in **Table 1.4**, the payback period of solar is less than half the payback period of wind. This makes sense since the wind turbine has a high capital cost and produces less than the PV panels over the season of interest.

The tilt angle of the PV panels and the effect on energy output is another aspect which was investigated.

Table 1.5: Roof tilt angles

Current Roof Tilt Angle On Dorm 2 and Dorm 3	18.4°
Optimal Roof Tilt Angle	13.8°

Table 1.5 above was created by solving a parametric analysis in order to optimize the total energy generated as a function of the roof tilt angle. The current roof tilt angle of the dorms with arrays is about 4.5 degrees from the optimal angle of 13.8 degrees. **Table 1.6** below shows the effect this difference has on production.

Table 1.6: Theoretical energy generation with optimal roof tilt angle.

Output at Optimized Roof Tilt Angle (kWh/day)	5106
Percent Increase	0.1%

Though there is an increase in PV energy output when the roof tilt angle is optimized, this increase is insignificant. In addition, the cost of building the structure and the increased risk posed by allowing strong winds to flow underneath the panels weigh down this option. The previous calculation shows that there is no practical reason to adjust the angle of the panel.

The increase in production observed by tracking PV panels was also investigated. Solar tracking panels rotate about a horizontal axis in order to follow the sun throughout the day. This increases the panel efficiency since it can catch the most direct sun rays throughout the entire day instead of just a portion of the day.

Table 1.7: Solar tracking panel energy generation and percent increase from current panel arrangement.

Output with Solar Tracking Panels (kWh/May-Sept)	5181
Percent Increase	1.6%

Solar tracking panels produce more energy than the fixed tilt panels that are currently installed. However, the increase in energy production is a marginal 1.6%. Since solar tracking panels pose the same problems as above, and are also more expensive and complex, this minimal increase is not worth the added investment.

Monitoring and Data Logging System

To more fully understand the continual output of the solar panels and wind turbine, a combined monitoring system is necessary. Such a system would ideally observe wind speed and solar insolation to calculate potential energy production. More importantly, the monitoring system should meter the actual production of the solar panels and the wind turbine, as well the total energy that is used from the inputs. From this, SML will be able to better understand the actual output from either source. As of now, island staff can determine when the battery banks are charged but are unable to determine how much energy they receive from each source. There is also no way to detect a decrease in production from either device.

The current monitoring system has been challenging to work with. The data is collected and logged in the AIRMAP database. Therefore, all the data files must be retrieved from AIRMAP staff. This is an inefficient practice since it necessitates a middle man. Though the AIRMAP staff is helpful, SML would prefer easier access to the data they are interested in. Another problem with the current monitoring system is that the OutBack Mate, which monitors the output of the two PV arrays, has numerous columns of minute by minute data which are difficult to categorize. It is also a large volume of data which Microsoft Excel has trouble handling. Furthermore, bugs were found in the data that had been logged by the MATE. An example can be seen in the table below.

Table 1.8: Excerpt from the OutBack Mate data string.

Timestamp (year,month,day,minute)	PV Current	PV Voltage	Daily kWh	Battery Volts
2011,01,01,0000	0	2	118	52.8
2011,01,01,0001	0	0	0	0
2011,01,01,0002	0	0	0	0
2011,01,01,0003	0	2	1181	0
2011,01,01,0004	0	2	118	0
2011,01,01,0005	0	2	118	531.1
2011,01,01,0006	0	2	118	53.1

In **Table 1.8**, the highlighted values show the obvious coding bugs. With data for every minute of every day, there is too much data to ensure these errors are deleted. Another problem is that

the OutBack MX60 charge controller turns off when the batteries are fully charged. At this moment, the data stops being logged. An example of this can be seen in **Figure 1.1** below.

Figure 1.1: Output recorded by the OutBack charge controllers from August through September 2010.

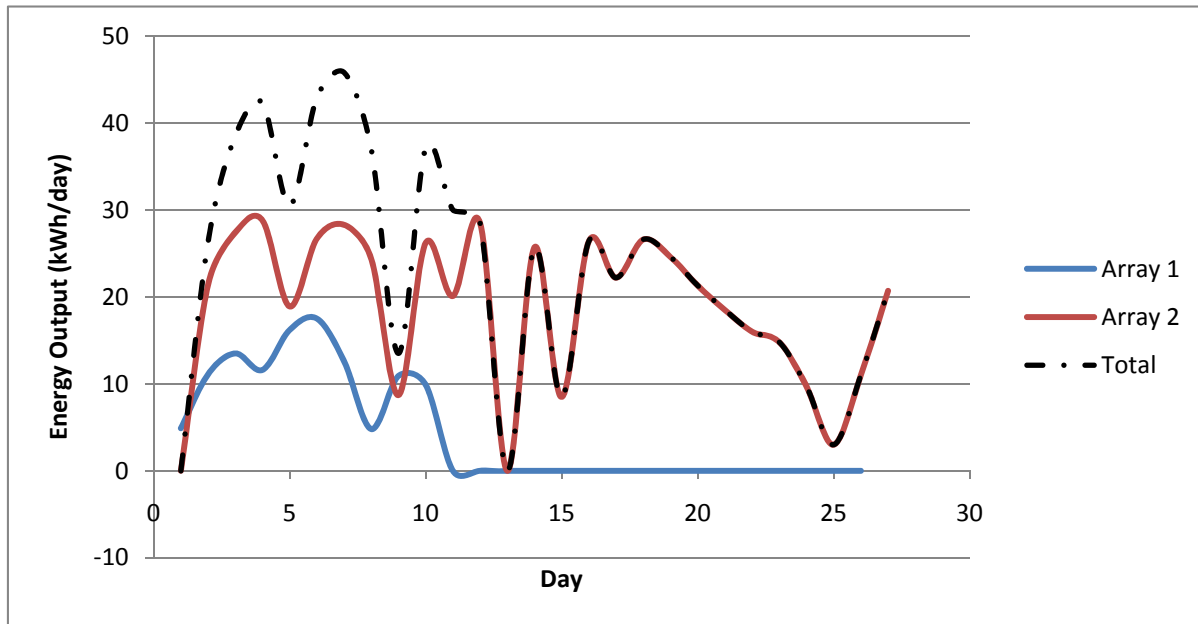

This data shows that Array 1 had no output for most of August and September while Array 2 continued to produce; a highly unlikely situation. This difference is due to the fact that the charge controller for that array had turned off when the batteries were topped off. So, instead of measuring how much energy is produced, this is a measure of how much solar energy is used by the green grid and batteries. Clearly the PV panels are producing more energy than what is recorded. This hinders our ability to calculate the actual energy output of the arrays.

Companies that develop user friendly data logging and analyzing programs were contacted for alternative options. The companies that were consulted with are OutBack Power Systems, Righthand Engineering, and greenHouse Computers. Though there are many more companies that provide such systems, these companies merely represent the characteristics in logging systems that are attractive for the SML system.

Table 1.9: Three options for data collection and display.

Group Name	Compatible with OutBack Power Systems	Hardware Costs (\$)	Software Costs (\$)	Installation Costs (\$)	Total Costs (\$)
OutBack Power	YES	350	0	100	450
greenHouse Computers	YES	415	149	500	1,064
Righthand Engineering	YES	1,200	1,160	500	2,860

The first potential option for data logging would involve purchasing the OutBack FLEXnet DC to monitor the output of the wind turbine. This data would then be read by the MATE which currently acquires the solar array data. This would be a minor improvement to the current system since wind turbine energy output could be monitored. However, the previously mentioned problems with the OutBack Power System would still exist.

Another option is to purchase a program from greenHouse Computers. This program uses the data which comes in from the OutBack MATE and runs the desired data analysis. The program is also compatible with Bogart Engineering products. Although the Bogart Pentemetric meter is currently non-functional, it would be able to be integrated into this system. The greenHouse program is server capable and data could be gathered and displayed on any computer connected to the server. Additional hardware would need to be purchased to read the output of the wind turbine. This would be beneficial for allowing SML staff to gain direct access to the data.

Another option is to work with Righthand Engineering to install their data analysis program. Righthand Engineering also works with data read by the OutBack Mate to turn it into a more user friendly format. The program is also server capable. An additional benefit of using Righthand Engineering's systems is that the company has developed a kiosk display which is shown below.

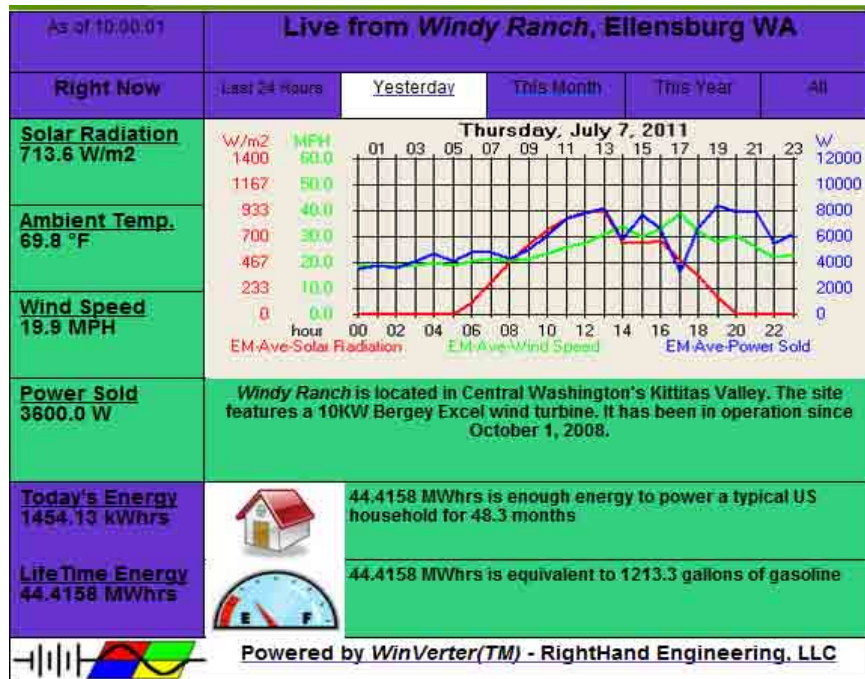

Figure 1.2: Screen shot from the kiosk display from Righthand Engineering.

This kiosk is versatile in that it can display a range of values from solar radiation to energy output of the wind turbines over the span of a day or over the span of a year. This kiosk would serve to educate the dynamic population of SML about the renewable energy systems on the island. However, as shown in **Table 1.10**, this system is rather expensive in comparison to other options.

Recommendations

The results section is based on the assumption that all the energy produced by the PV panels and the wind turbine is used by the green grid. Additionally, it assumes that this energy production takes the place of diesel energy production. This is currently not the case. The green grid is only hooked up to Dorm 2, Dorm 3, and the radar tower. To ensure that the most is made of the energy produced by the panels and the turbine, it is recommended that SML utilize all the energy generated from the existing renewable energy infrastructure.

Since the PV panels produce more energy and are a cheaper investment, it is recommended that SML expand the green grid with PV panels as opposed to another wind turbine. This is further supported by the fact that the PV panels have a payback period of 26 years and the wind turbine has a payback period of 65 years. Additionally, the wind turbine requires laborious installation, while PV panels are relatively simple to transport and install. As passive elements with no moving parts, they require minimal maintenance over their life.

If more panels are purchased, it is recommended to find a tilted surface between 13 and 20 degrees based on the theoretical analysis. This range represents the most optimal energy generation (+/- 1.5%). Dorm 1 is a good candidate based on location, as it is south facing with the same tilt angle as the other dorms.

Another idea is to look for southwest facing surfaces, as they would receive the greatest solar radiation in the afternoon when the island's power demand is highest. This solution might be an easy way to save money on a battery bank size as the electricity would be consumed as it comes in, without being stored.

With regard to data acquisition, the Righthand Engineering kiosk and data logging program seems to have favorable characteristics for the system. Though it is the most expensive, its kiosk is perfect for displaying data to the general public. Such an addition would be greatly received by the SML community.

Before any move is made, however, it is recommended that the SML staff understand exactly what is not functioning in the current system and why. Perhaps starting the computer programming from scratch in order to pull just the values that are needed by SML would be the easiest solution for the data logging issue.

Diesel Generator and System Power Factor

Background

Power is delivered to the majority of Appledore Island's buildings through a diesel generator. Currently, there is a 27 kW Caterpillar generator (Generator #3) which powers all campus buildings besides those on the green grid. Recently, the generator has tripped multiple times, causing a power outage across the campus. This will happen when the electricity demand spikes well above the rated power or current levels. Unfortunately, the generator does not trip at the same time of day every time it goes down. For this reason, it is not entirely obvious what loads, specifically, cause this problem.

Additionally, island staff has observed a low system power factor. This typically indicates that a large part of the generated power does not contribute to useful work (measured in kilowatts).

Objective

Investigate the impact of the system Power Factor as a capacity constraint on the diesel generated electricity. Also, explore the potential to reduce peak loads by understanding trends in island electricity consumption.

Theory

Energy is used in a variety of ways on the island. From refrigerating food to pumping sea water into labs, the humans on Appledore Island are constantly demanding energy. From an electrical standpoint, energy is most commonly quantified through a unit known as kilowatt hours (kWh). Power is the time rate of energy most commonly expressed in a unit called kilowatts (kW). Much like the way speed is the change in position per unit time, power is the electrical analog; it is the time rate of energy per unit time. When the energy demand in a particular time frame (power demand) is too high, the diesel generator can have a hard time keeping up, which can cause the generator to trip and the island to lose power.

The two main types of electrical circuits are called direct current (DC) and alternating current (AC). In a DC circuit, power is calculated as the product of the electrical current and voltage. In an AC circuit, there are three different types of power. Every time the current (and thus energy flow) changes direction, a portion of that energy does not return because it has been consumed. This is the real power which was previously discussed (kW). The portion of the power that does return is known as the reactive power and is expressed as a volt-amp-reactive (VAR). The overall effect of these two quantities is known as the apparent power and is expressed in volt-amps (VA).

Power factor is defined as the ratio of real power to apparent power. The difference between the two is made up by the reactive power. In vector space, the apparent power is the sum of the real and reactive power. Together, these three values form “the power triangle.” This is illustrated in **Figure 2.1**, below.

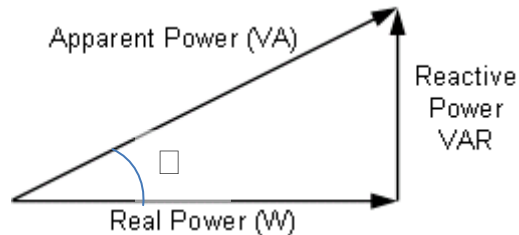

Figure 2.1: The power triangle.

Procedure

This assignment has two parts to it. The first is an evaluation of the island’s energy consumption in order to understand the trends exhibited over the course of a season. The second part is an analysis of the system power factor, as well as recommending ways which this can be reduced. These two aspects are closely related.

In order to explore power trends, an Allen Bradley Powermonitor 3000 was used. This product is used to gain insight into an industrial sized electrical power system. It has a metering accuracy of $\pm 0.2\%$ Volts, $\pm 0.2\%$ Amps, $\pm 0.05\%$ Hz, and $\pm 0.4\%$ Watts. For this analysis, these uncertainties are within an acceptable range.

To measure electrical information at any point in the electrical grid, the Fluke 289 Digital Multi-meter was used. This equipment has a metering accuracy of $\pm 0.025\%$ V and $\pm 0.15\%$ A. This device was only used to get estimates of power information, so these uncertainties are also acceptable.

The 2010 season on Appledore Island was logged using an Allen Bradley Powermonitor 3000 at 1-minute intervals. These logs were compiled into an MS Access database where one has the potential to look at a variety of information regarding power consumption on the island.

2011 power data is logged at 5 minute intervals beginning on June 10. The Powermonitor 3000 sends the data to a laptop computer nearby which is running RS Power. This is the computer program which logs the data and allows the user to view information on trends, minimums and maximums, as well as real time power consumption.

Diesel Power Consumption

With this information, a better understanding of daily and seasonal power trends and characteristics will be obtained. From here, recommendations on how to shave peak loads on the island can be made. By understanding more intelligent ways to load the generator, it will not trip as frequently, if at all.

System Power Factor

The Powermonitor 3000 logs the system power factor. Using the “power triangle,” information about reactive power and apparent power can be determined. After a strong understanding of reactive power trends on the island is obtained, a capacitor bank will be sized in order to increase the rated power factor, and thus the capacity of the generator.

Results and Analysis

Energy Consumption

From the MS Access database, energy consumption for the 2010 season was observed and is illustrated in the following **Figure 2.2**. The primary vertical axis shows the daily electrical energy consumption, while the secondary vertical axis shows the amount of people at dinner that night. In general, because the head count at dinner is assumed to represent the entire day’s population, one would expect to see a time shift in correlation between people and energy usage. That is, large groups arrive late in the day to Appledore Island, and the energy footprint that they bring with them would not be noticeable until the next day.

By looking through the kWh data, it was determined that Appledore Island’s energy demand last season was 446.7 kWh +/- 170 kWh at the 95% confidence level. This does not tell the whole story, however, as classes (and thus, people) are constantly coming and going. The high precision interval suggests that something else is going on here. The time history of the average kWh proved to be more useful.

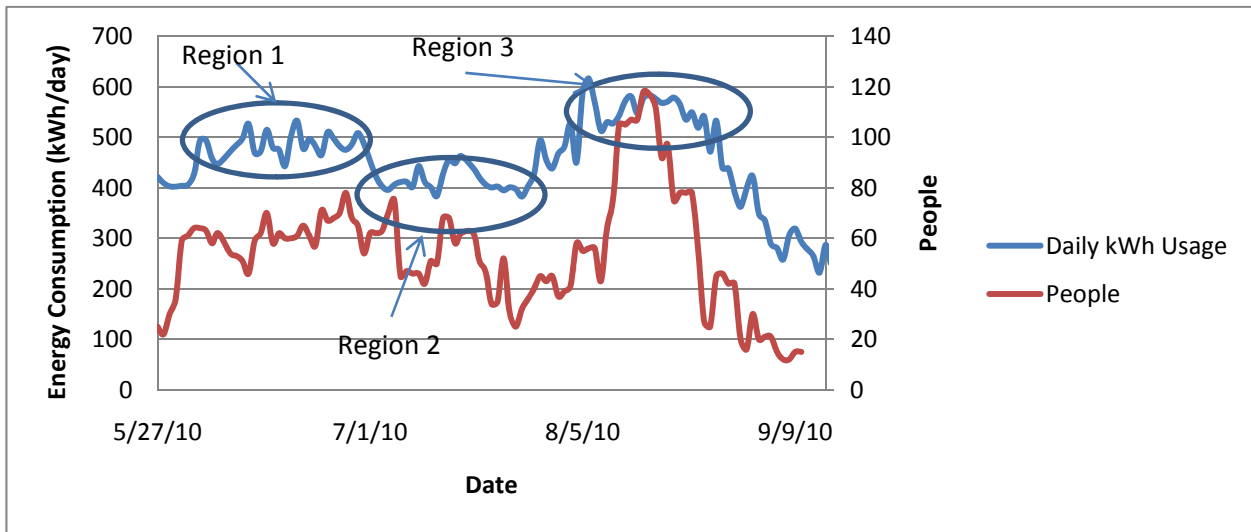

Figure 2.2: Energy consumption and island population as a function of the day of the year.

The following **Table 2.1** summarizes the correlation between island population and energy consumption:

Table 2.1: A summary of electrical energy consumption for the 2010 season.

	Average Consumption (kWh/day)	Precision Interval [P = 95%] (kWh/day)	Average Population (people)	Average Consumption per Person (kWh/person-day)
June	486	44	62	7.8
July	420	54	48	8.8
August	540	90	69	7.8

These results can be deceiving. By referring back to **Figure 2.2**, it is clear that for 1 week (between August 11 and August 18) there were about 60 people who arrived. The 150% increase in population did not result in a 150% increase in energy consumption. This has the effect of lowering the average consumption per person for the month of August. August was expected to show a higher consumption, as the Reverse Osmosis machine ran for about three straight weeks on the larger generators.

Generator Shut Down

On the topic of generator failure, energy consumption can only say so much. So far, it was determined that each person demands approximately 8kWh/day, which results in an average power draw of about 350 W. This method of turning energy usage per day into average power is irrelevant, however, when it comes to a generator failure. The generator shuts down at times of instantaneous loading.

The following **Table 2.2** summarizes the 6 times that the small generator (Gen 3) has tripped since July 2, 2010, which is when the current generator was installed.

Table 5.2: Time of day when Generator 3 was shut down due to high power demand.

Generator #3 Shut-Down Event	Time of Day
July 4, 2010	2:15 p.m.
July 26, 2010	5:41 p.m.
June 4, 2011	3:49 p.m.
June 9, 2011	12:17 p.m.
June 10, 2011	11:43 p.m.
July 7, 2011	9:45 p.m.

Though 3 of the 4 most recent Generator #3 shutdown events were not logged by the Power Monitor 3000, the first two outages were logged and are currently stored in the MS Access database. The first shutdown of Generator #3 occurred just two days after it initially started up. There were multiple high current warnings in these two days. The logged data reveals that the current would infrequently reach over 40 A in these days. Finally on the 4th, the generator shut down due to a false high coolant temperature reading. The issue was a faulty coolant temperature sensor in the radiator.

The next generator shutdown occurred on July 26, about three weeks after the initial shutdown. At around 5:45 p.m., the machine shut down due to overcurrent. The data shows that at this time, the real power spiked to over 35 kW, nearly 30% higher than its rated capacity. The power profile for this day is shown in the following **Figure 2.3**, along with the corresponding power factor, which will be discussed in further detail later.

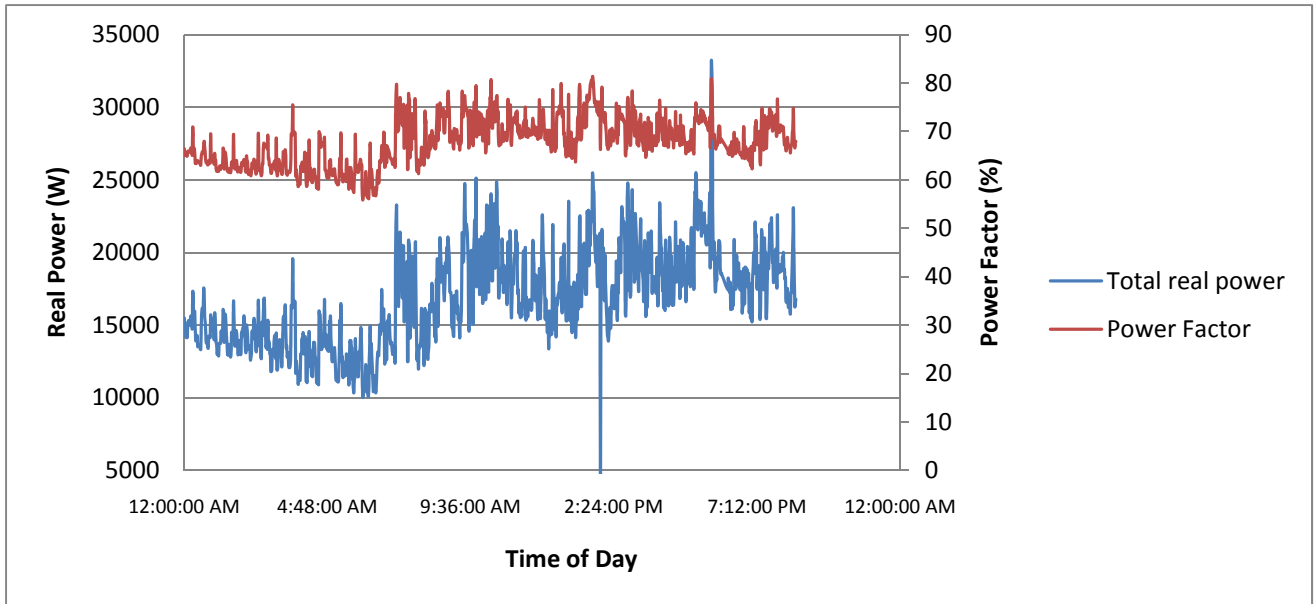

Figure 2.3: Power demand profile as well as the corresponding power factor for July 26, 2010. The generator shut down at approximately 5:40 p.m.

The power profile is completely normal, if not low, until the surge of current around 5:40 p.m. A large and instantaneous power demand hit just before dinner, causing the generator to shut down. By looking at the reactive power profile for this day in **Figure 2.4**, one seeks a better understanding of what type of load or loads caused the surge.

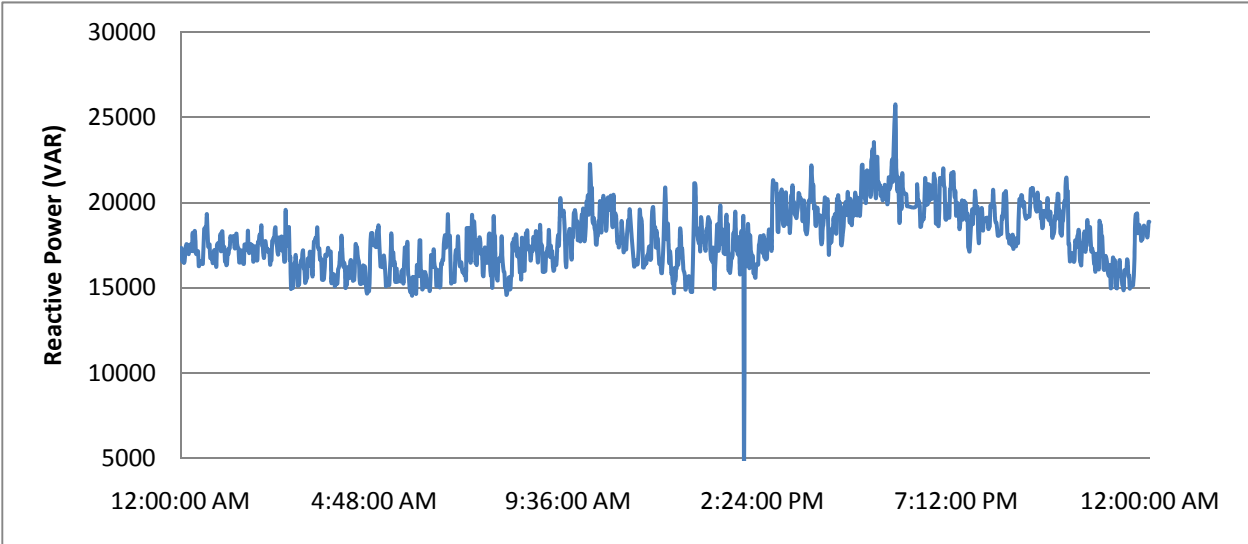

Figure 2.4: Reactive power profile for July 26, 2010

A spike at 5:40 p.m. in **Figure 2.3** suggests that the instantaneous increase of real power (kW) demand at the same time as an increase in reactive power demand corresponds to an inductive element on the grid. It can be estimated at about 10 kW and 5 kVAR. The 2009 engineering interns could not find a piece of equipment that drew that much power which was not continuously running (the salt water pump was reported to draw about 6 kW, but it runs 24 hours a day). After speaking with Ross Hansen, it was determined that this power draw was most likely caused by switching the green grid batteries to the diesel grid. This has an estimated power draw of 7 kW. Additionally, this circuit has multiple transformers and inverters which consume a great amount of reactive power.

The engineering team on Appledore Island has changed settings on the Outback charge controllers so that the power draw is about half as much. Though this means it would take double the time to charge the batteries, it greatly reduces the risk of tripping the generator.

Unfortunately, the next three generator failures from the 2011 season were not logged in the RSPower program. This makes investigating their causes quite difficult. However, every time a generator has shut down this season, the generator logs indicate that the instantaneous power has spiked to over 30 kW.

To investigate this problem further, a histogram was created which indicates the frequency of maximum power events over the course of a month.

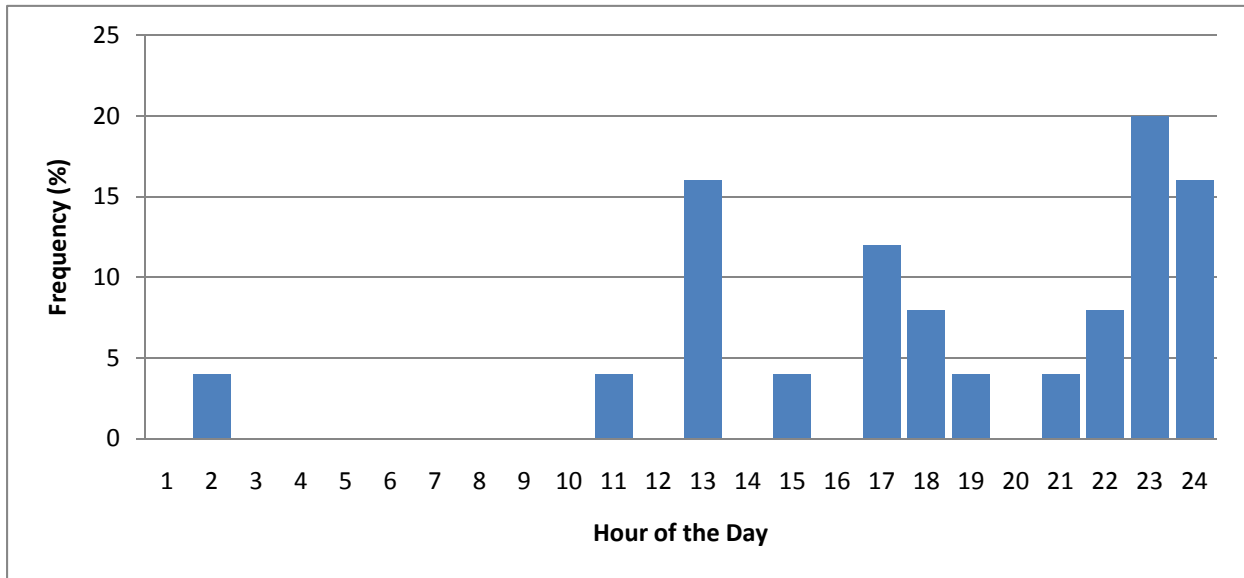

Figure 2.5: Histogram showing the frequency of maximum power occurrences at various hours of the day.

Though the histogram has only 25 days of data, it appears to be slightly bimodal in nature. Nearly 50% of maximum real power events occur after 9 p.m. Approximately 30% of maximum real power events happen between 4 p.m. and 7 p.m. This figure indicates that a generator failure is most likely to occur at these times when the power is high. The following histogram (Figure 2.6) illustrates how frequently the generator failed at various hours of the day:

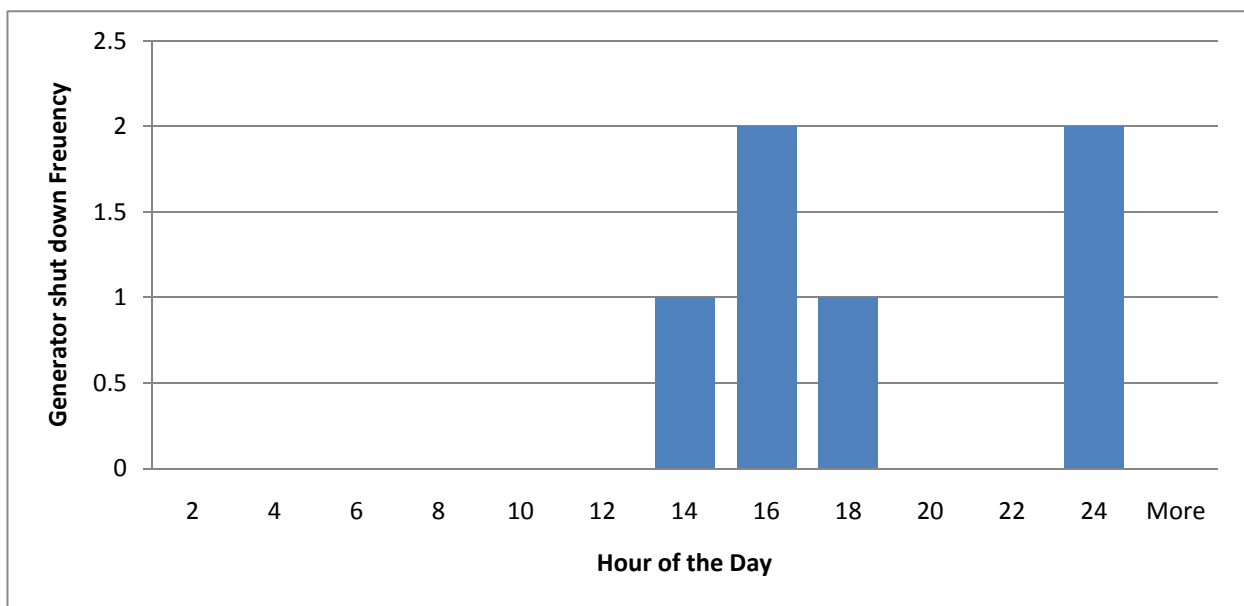

Figure 2.6: Histogram showing the frequency of generator shut down events at various hours of the day.

The histogram shows that generator shut downs coincide with maximum loading times in the day. It must be noted, however, that the resolution of the second histogram is far worse due to the limited amount of data (which is a good thing).

It is one thing to know when a power outage is most likely to occur, and it is an entirely different thing to understand why that outage occurs. With the green grid battery charging rate reduced, other power spikes in the daily power profile were investigated.

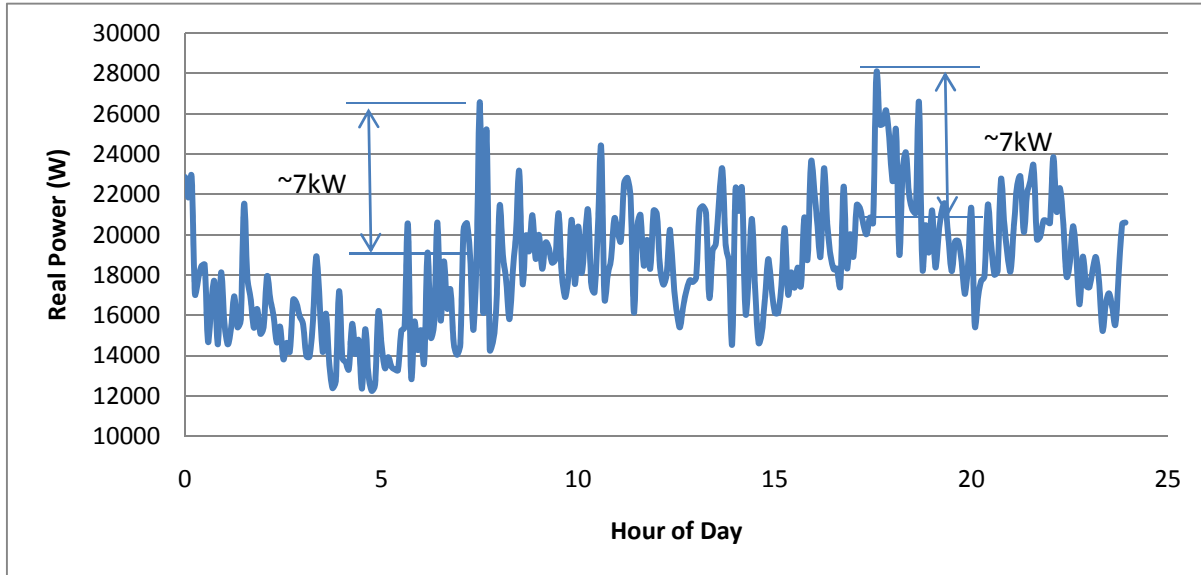

Figure 2.7: Power profile for June 16, 2011.

On June 16, 2011, there were 72 people on the island. **Figure 2.7** shows that in the late night/early morning hours, with no direct user consumption, the generator's real power load steadily decreases to approximately 14 kW. Demand then increases until a 7 kW spike at 7:30 a.m., which is when Appledore Island serves breakfast to residents. The power demand remains relatively low for the rest of the day. At approximately 6 p.m. (dinner time on Appledore Island) the power spikes yet again. A 7 kW increase is observed. Previously, the 7 kW spike was attributed to the charging of the green grid batteries. This can be ruled out in this case because of the reduced charging rate in the charge controllers. This was further investigated in order to get a better idea of this meal time power surge. The Fluke Power Digital Multi-meter was hooked up to the circuit breaker of the freezer and refrigerator compressors in the basement of Kiggins Commons. 1-second interval current data was logged both before lunch and dinner on the same day.

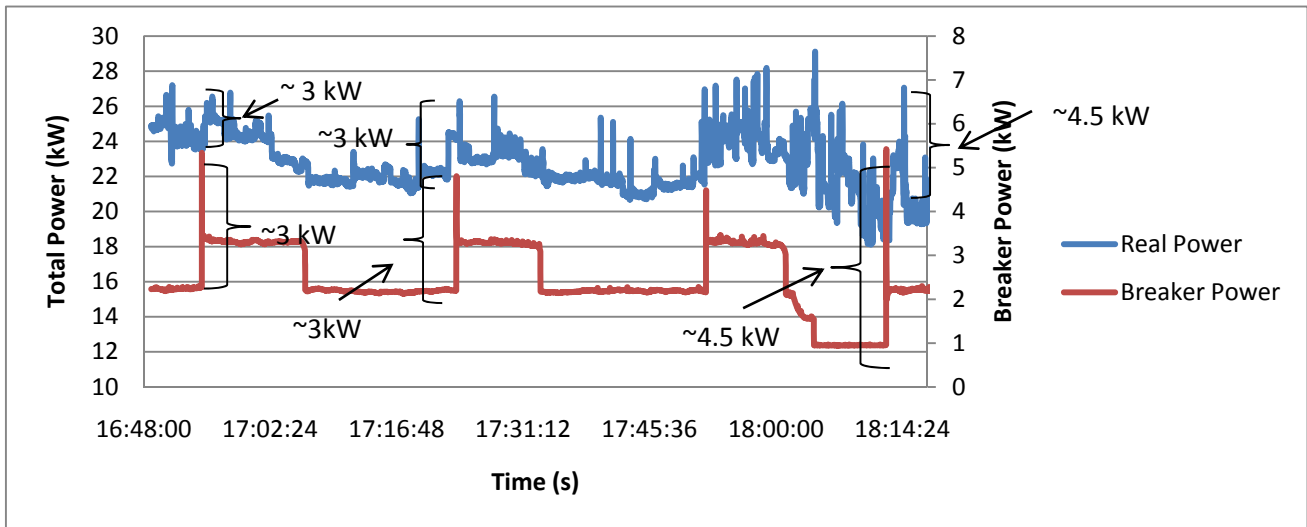

Figure 2.8: Simultaneous power monitoring of the entire grid as well as the circuit breaker for the refrigerator compressors.

Figure 2.8 shows an estimation of the instantaneous breaker power which was determined using the measured current. The figure shows the effect that the compressors have on the total electrical grid. The current required to start up the compressors is about 3 times higher than normal operation. This current corresponds to a power of about 4 kW for each compressor. That is approximately 15% of the total electrical load at any given time. These two compressors make up a big portion of the motor loads on the island. Other large motors that were identified are the salt-water pump (which is a continuous load), the well pump, the cistern pump, and the sewage pump.

The breaker power depicted in **Figure 2.8** is binary in nature. The interesting part, however, is that between “off” and “on”, one consistently sees a spike in power. This phenomenon is known as starting current. In electric motors, the start-up current can be anywhere from 3-10 times higher than normal operating conditions.

Using the Fluke 289 Multi-meter, starting currents for the large pumps on the grid were investigated. They are summarized in **Table 2.3**, below.

Table 2.3: Starting power for large inductive equipment on Appledore Island.

Inductive Equipment	Estimated Starting Power (kW)
Refrigerator Compressor	4
Freezer Compressor	3
Sewage Pump	3
Well Pump	7
Cistern Pump	2

These motor loads can be split into three basic systems: refrigeration, wastewater, and freshwater. Commonly, these systems are running concurrently. Imagine mealtime, for instance. People are in and out of the refrigerator, while simultaneously demanding a near constant stream of freshwater. If two of these pumps are running, all it takes is a third pump to kick on at a time of high demand (see histograms above) to kick the generator.

It should also be noted that many of these details are not visible on the standard 5-minute interval data which is generally monitored from the shop computer.

On July 7, 2011 at approximately 9:45 p.m., generator #3 shutdown due to high power demand and thus overcurrent. Though the majority of the analysis had been completed by this time, some information about this power outage is included in this report. A partial power demand profile is shown below:

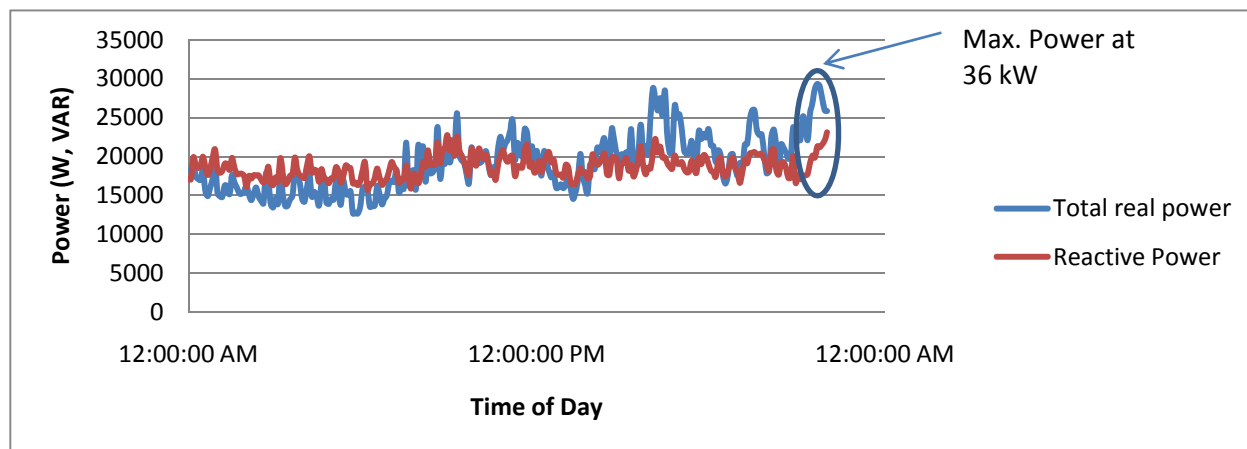

Figure 2. 9: Partial power demand profile up until the generator shut down at 9:45 p.m.

The generator shut down indicates two things. The first is that the primary cause of the shutdowns is not directly human induced. That is, connecting personal items to the grid such as laptop computers and cell phones does not directly trip the generator. Of course these loads are

not negligible, and more conscious loading should be practiced, but what ultimately will trip the generator is the start-up current required by some of the motor loads.

The maximum power value was taken from the Min/Max log, generated by the RS Power program. Though the sampling interval is set to five minutes (which is why the highest power shown on **Figure 2.9**, above, is 29 kW), the Min/Max log records the lowest and highest values for each parameter during the logging period. This indicates a near 10 kW load. Again, that would require about 200 people charging their computers on this generator at once. This is not likely, as there were only about 75 people on the island at this time.

Low Power Factor

The next part of this project was an evaluation of the system power factor on Appledore Island. **Figure 2.10** below shows the power factor as a function of normalized real power demand (ratio of the power to the rated power) over a week long period.

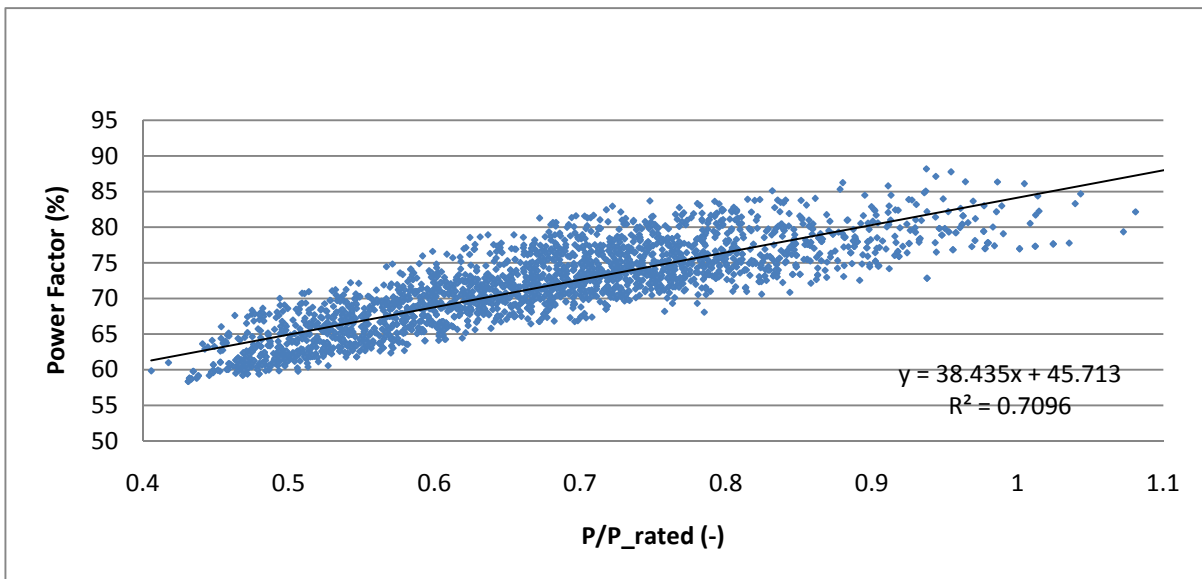

Figure 2.10: Power factor as a function of normalized power demand.

The graph suggests that, in general, the closer the demand gets to its rated capacity, the higher the power factor becomes. Currently, the island's electricity generation is characterized by a power factor that ranges from 65% to 85%. As the generator is loaded to its rated capacity, the power factor is increased.

With an understanding of the power triangle, this indicates that the reactive power remains relatively constant as the real power rises and falls throughout the day. Think about a right triangle whose vertical leg remains a certain height while the horizontal leg varies in length. As

the horizontal leg grows longer, (representing higher real power consumption) the cosine of the decreasing angle of the triangle would approach unity. This would be a perfect power factor.

To further illustrate this point, the standard deviations of both values were calculated over the course of 4 days. As a measure of scatter, the standard deviation will show how much more “constant” the reactive power is than the inherently fluctuating real power. The calculated standard deviation of the real power from June 13 to June 17 was 3.28 kW. The standard deviation of the reactive power over the same period was calculated as 1.74 kW. This represents a scatter nearly half the size of the real power consumption data.

In some ways, this is a favorable characteristic of the grid. That is, the system power factor is lowest at the lightest loads. When the generator is doing the least efficient job transmitting power throughout the grid, the least amount of power of the whole day is being demanded of it. On the contrary, when the generator is working hard to keep up with the highest demand of the day, the power factor is the highest; power transmission is most efficient.

Though the reactive load is usually fairly constant throughout the day, a few cases were found which indicated that there are some large loads (approximately 10 kW) that are introduced which have large reactive loads as well.

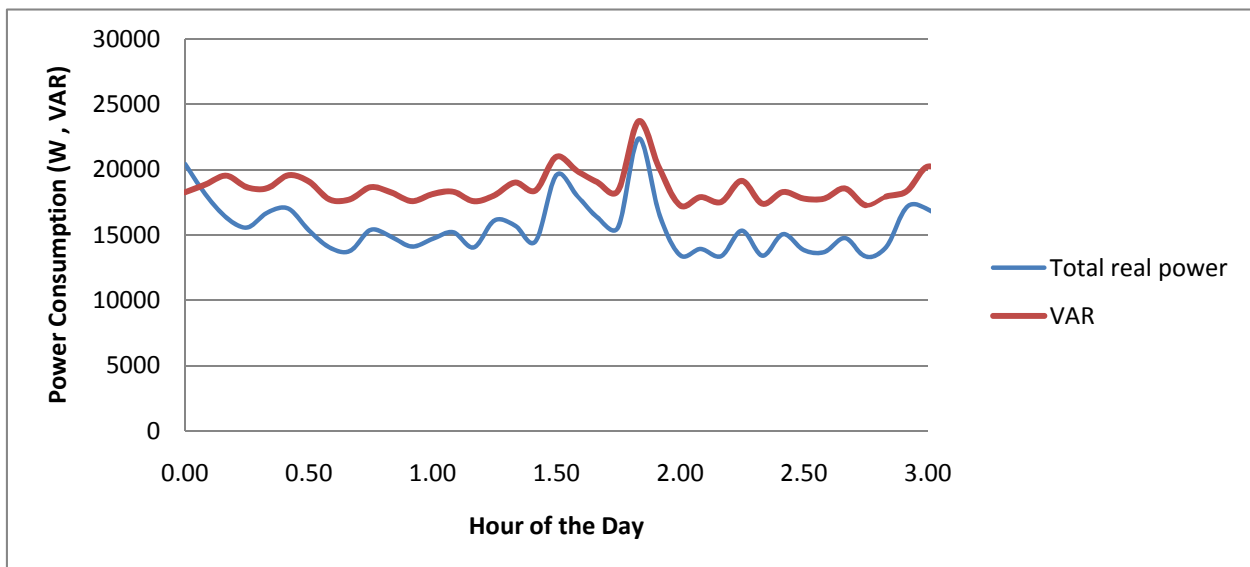

Figure 2.11: Large load that consumed both real and reactive power upon energizing.

Though this load’s identity cannot be confirmed, its energizing at approximately 2 a.m. suggests that it was not turned on by a human. Additionally, it is approximately 7 kW, with a reactive power draw of about 6 kVAR (power factor of about 75%). This makes it an inductive load. When this piece of equipment is turned on, a very large amount of current is demanded. This makes a generator shutdown all the more likely.

Recommendations

The first solution to this problem is to shave peak loads. That is, reduce power consumption at the time of day where the energy demand on the diesel generator is the most intense. By watching the peak loads every day for nearly a month, it was determined that the power consumption on Appledore Island is the highest around mealtimes (particularly breakfast and dinner), and was observed to be high from dinner until bed time. Much like the culture of water conservation on the island, implementation of various electricity-usage altering techniques could help lighten the load on the strained generator.

It has been estimated that a charging computer laptop draws about 40 – 50 W. If 50 people charged their laptops at the same time in the morning hours, this would take away a presumed 2.5 kW load from later in the day and instead apply this load during the early hours where power demand is low.

There are also methods to take the laptop charging off of the diesel generator load completely. At this point, the green grid burns lots of energy through resistive heaters. Instead of heating a room, this energy should be fed into charging stations either in the Palmer Kinne laboratory or in dorms 2 or 3. Students would be encouraged to use this charging station either overnight or during meals, and would be discouraged from plugging into the outlets in Kiggins commons.

Though a culture of energy conservation would be a great thing on the island, it is not clear whether or not it would have a significant effect on preventing large surges of current demand on some of the larger equipment.

There is no systematic defense against this surge of power demand from the generator. In other words, at times where user demand is high because of various battery charging, the refrigerator door opening and closing, etc., there is nothing that prevents the well and cistern pumps from kicking on. These pumps are controlled by float valves and they act independently of each other as well as the rest of the system. When the generator is being strained, all it takes is a few more kilowatts of instantaneous power demand to overload it. A simple control system might do the job, but the added complexity and cost seem to outweigh the benefits of preventing an already unlikely event.

One solution to this random motor start-up problem is by reducing the current draw of this equipment. This can be done by reducing the amount of reactive power that is consumed by the equipment by supplying the circuit with reactive power in some way other than from the generator.

Power Factor Solutions

One of the most common solutions to improving the grid's power factor is the introduction of capacitor banks. The idea is that inductive elements will consume reactive power in order to function. The physics behind the situation can be easily understood. When a voltage is applied across an inductor, the current must build according to a first order response. Thus, the current is said to *lag* the voltage. Capacitive elements, on the other hand, tend to provide reactive power. When current is sent through a capacitor, the voltage will build as charge collects between the plates. For this reason, the current is said to *lead* the voltage. This complementary behavior can be used to reduce the reactive power demand, and thus decrease the apparent power in the system.

It has been decided that the generator shut downs are caused primarily through the large inductive motors on the island. This motivates the addition of capacitor banks.

With an understanding of the “power triangle,” relating reactive power to real power through the power factor, a capacitor bank was sized which would greatly improve the performance of our existing grid, by reducing the reactive power demand. The following figure shows the apparent power profile in VA over a four day period from June 23 to June 26, 2010. Additionally, the figure shows how the apparent power would be corrected, and the resulting percent reduction.

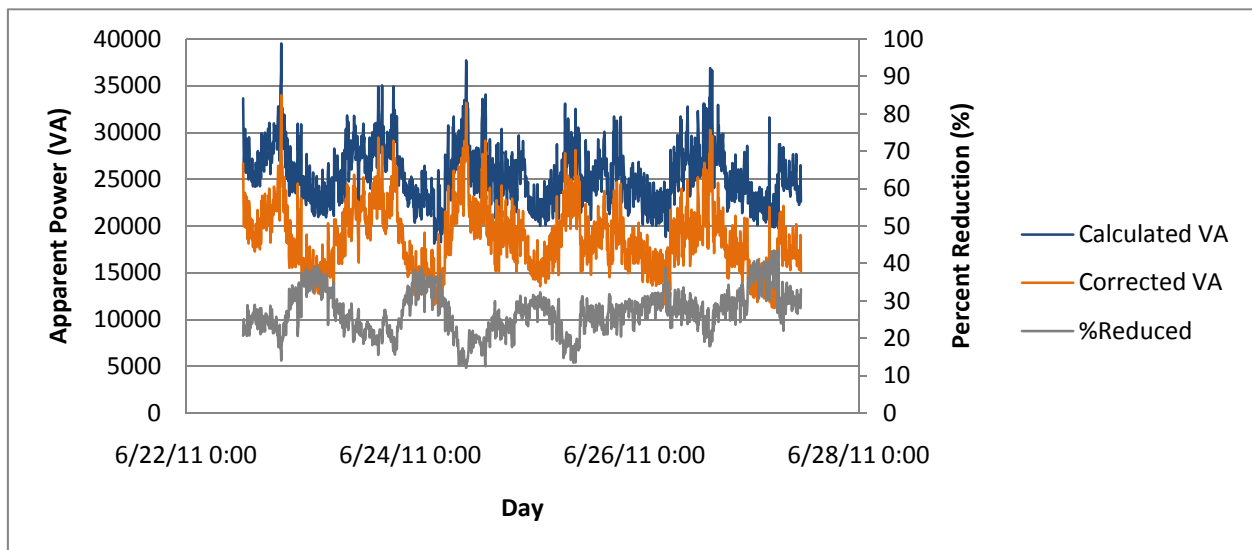

Figure 2.12: Measured apparent power, projected corrected apparent power, and percent reduction in apparent power for June 23 – 26, 2011.

This model suggests that peak apparent power loads can be reduced by more than 10% with an added capacitor bank.

The analysis began only over a 4 day period to keep things relatively simple. When a basic size was determined, the analysis was moved to the entire 2010 season. The values presented are daily minimums, which should correspond to the times when the apparent power load is highest.

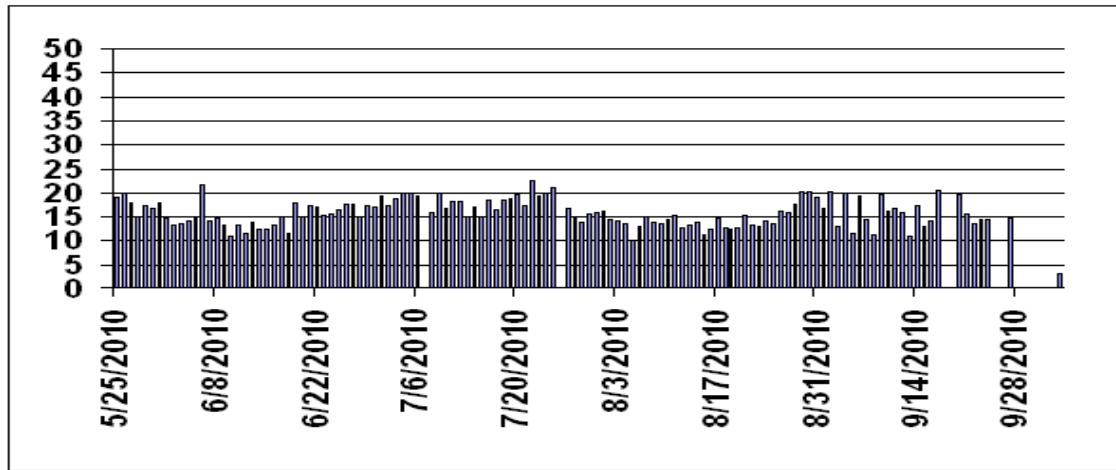

Figure 2.13: Reduction in apparent power demand with respect to the daily minimum apparent power for the entire 2010 season.

Before harmonics considerations, the appropriate capacitor bank size for the system is 15 kVAR. That is, it will provide 15 kVAR to inductive loads. There are a few factors that were considered regarding the implementation of this bank.

The first idea is to split the 15 kVAR bank into three 5 kVAR banks that would be spread out over the grid.

Justin Eisefeller, of Unutil Service Corporation, has also made a few other design suggestions. The units should be installed in a covered and protected environment. This eliminates the idea of having them directly adjacent to large inductive equipment, but certainly improves maintenance costs as well as the threat of damage. Also, Justin recommends installing the units near a 3-phase, 480 V distribution panel.

The units are rectangular boxes. The drawings are shown in **Figure 2.14**, at the top of the next page. From the electrical one-line diagrams, as well as space considerations, appropriate locations were determined.

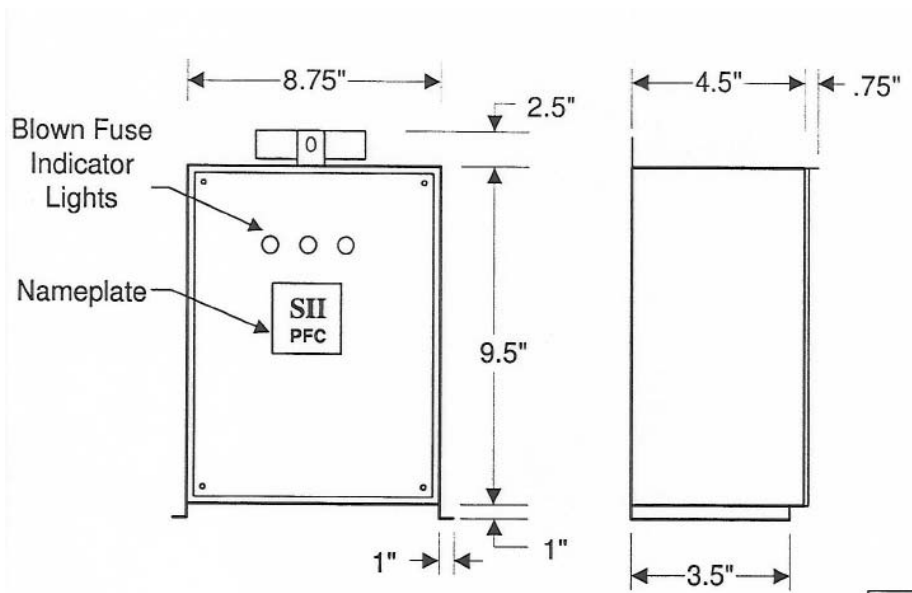

Figure 2.14: Dimensional information provided by Steelman Industries, Inc.

Potential locations for these 5 kVAR capacitor banks are discussed below. No dimensions are drawn to scale. They are intended to give rough dimensional sense.

Utility Building:



Figure 2.15a: Utility building distribution panel potential location #1.



Figure 2.15b: Utility building distribution panel potential location #2.

Kiggins Commons Basement:



Figure 2.16a: Kiggins Commons distribution panel potential location #1.



Figure 2.16b: Kiggins Commons distribution panel potential location #2.

Radar Tower:



Figure 2.17a: Radar Tower distribution panel potential location #1.



Figure 2.17b: Radar Tower distribution panel potential location #1.

Each unit could potentially be connected at any point within the electrical system. From the specifications, a 5 kVAR unit attached to a 480 V distribution system is rated at 6 A. Additionally the unit would require a 14 awg wire size. This unit would be connected directly to a voltage breaker so that it could be turned on and off. The units have a life expectancy of 20 years. These particular capacitor banks weigh approximately 13 pounds each.

Justin Eisfeller and Mike McCarthy from Unitil Service Corporation have, as a budgetary estimate, predicted that the equipment and installation for each unit would be about \$1000.

Before any capacitor bank is to be installed, a thorough harmonics analysis should be performed on the current electrical grid. An improper introduction of capacitors to a system could make the system unstable. Also, if the power factor was ever corrected past unity, it is said to be a leading power factor. This is a situation that must be avoided, for if the correction was too great, the results would be counterproductive.

It was mentioned that the units should be close to circuit breakers. These capacitors would not need to be hooked up to the grid at all times. In fact, it would be desirable to have them only running when the loads are high. This would be a practical way to avoid instabilities.

One robust way to go about this would be to monitor the reactive power early in the season. When the reactive power reached above approximately 17 kVAR, (giving a 1% cushion) the capacitors would be introduced to the circuit. At the end of the season, when the load drops below the 17 kVAR threshold, the capacitors would again be switched off the grid to avoid generator problems.

A proper implementation of these capacitor banks would improve the system power factor at Appledore Island greatly, thus increasing the capacity of the existing generator.

Increase Fresh Water Supply to the Well

Background

Appledore Island currently relies solely on the groundwater around the well for fresh water. While the well is sufficient for the majority of the season, it tends to run low towards the end of the season, forcing the island to depend on the energy intensive reverse osmosis machine. In order to save money and reduce energy demand by making this machine obsolete, water can be siphoned from Crystal Lake to recharge the well. This was first attempted last season, but the introduction of Crystal Lake water to the well immediately caused a spike in the well water's turbidity, forcing the island to start the reverse osmosis machine. This indicated that unfiltered Crystal Lake water is not suitable to be added to the freshwater supply. SML would like to use gravity driven slow sand filtration to treat this water before using it, and needs to determine the best way to implement such a system. Guidance for this task was provided by Dr. Robin Collins of the University of New Hampshire, who suggested two different sand types to test in the filters.

SML has a permit to legally withdraw a fixed amount of water from the lake based on the estimated volume. Since this permit determines how much water can be sent through the filters to ultimately recharge the well, a better estimate of Crystal Lake's volume is needed.

Objective

Determine if slow sand filtration is a viable option for charging the well with Crystal Lake water. Additionally, obtain a more accurate depth profile of Crystal Lake.

Theory

Filtration is a water purification technique used to decrease the turbidity of water by removing suspended solids. Turbidity measures the clarity of a liquid, with lower turbidity measurements associated with fewer suspended particles. Slow sand filters are typically used to bring water from 10 nephelometric turbidity units (NTU) to in the range of less than 1 NTU by removing these suspended solids. This technique utilizes several processes beneficial to water purification including settlement, organism removal, and straining. The process is relatively inexpensive and simple; gravity drives the water through a sand bed at a slow flow rate and particles are trapped in the sand as the water passes through. A biofilm forms on top of the sand called a *schmutzdecke*. The organisms in the *schmutzdecke* trap particles and help lower the turbidity of the water passing through the sand.

Another method of quantifying sand filter performance is with a dimensionless quantity known as pC^* . pC^* is defined by the following relationship:

$$pC^* = -\log(C/C_0)$$

where C is the effluent turbidity level and C_0 is the turbidity level of Crystal Lake. This normalized value is a more meaningful way to quantify the different sands.

Procedure

Two sands were tested in order to compare their performance as a slow sand filter medium. These sands were labeled Sand A and Sand B. Sand A was the coarser, cheaper sand. Its gradation report showed that the sand grain size was highly inconsistent, showing many different grain sizes in the sample. The majority of the sand ranged from size 12.5mm down to .850mm. In contrast, the finer, more uniform, and more expensive Sand B had a grain size between .425mm and .46mm.

Before starting to design the filter, a steady flow of water from Crystal Lake was needed. A tee fitting was used to split the siphon, allowing the majority of the flow to continue through the pipe and empty to a small pond near the filters. The portion of flow needed for the filters was then split in two. These two flows were controlled by separate globe valves, which governed the flow into each filter with more precision.

Two plastic trash bins were used to support the filter media because they were inexpensive and readily available. Wire mesh was laid on the bottom of these trash bins to support a 4.5 inch layer of gravel and prevent it from blocking the exit holes. A window screen was then placed between the gravel and sand layers to minimize sand seeping into the gravel.

Water entered the filters through a PVC pipe which was laid across the top surface with holes drilled in it to utilize the sprinkler effect.

To collect the water from the bottom, 26 small holes were drilled about two inches up from the bottom of each bin. This was done around the outside, as opposed to in the center, due to the uneven bottom of the trash bin. After flowing out of the filter through these holes, the water was collected in the lid of the trash bin, which was flipped upside down and put under the filter, acting as a collecting tray. Since this collecting tray was deepest around the outside, the water could be easily collected. To withdraw the water for testing, holes were drilled near the edge of the tray and a small ball valve was attached. Initially, a screen was used to protect the filter from the elements and a layer of Plexiglas was later added to keep the rain from skewing results. This allowed the vital sunlight to reach the sand surface, promoting *schmutzdecke* growth. The collecting tray also needed to be protected from rain since its diameter is larger than that of the filter, and was not covered by the Plexiglas. A plastic tarp was stapled and tied around the outside of the bin to prevent rain or organisms from entering the collecting tray. Two layers of cinder blocks resting on a piece of plywood were used to elevate the filters in order to take samples from the tray.



Figure 3.1: Both filters shown in final pilot test design.



Figure 3.2: Drainage holes and collecting tray

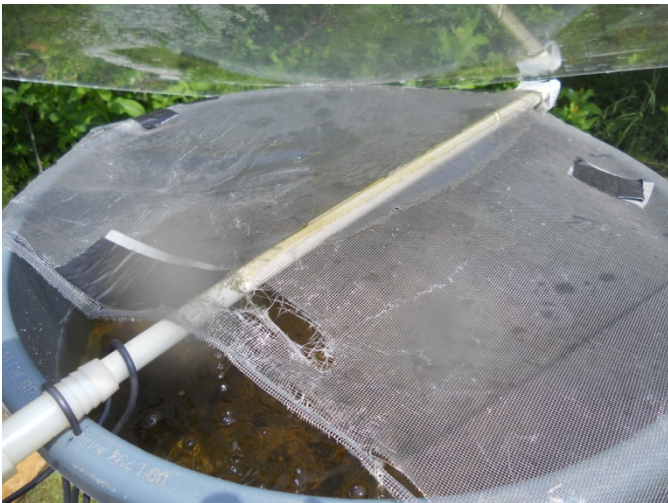

Figure 3.3: Top of Filter



Figure 3.4: Schmutzdecke forming after 6 days of testing.

Once the filter began operating, turbidity measurements were taken several times each day. Water samples from both filters as well as from Crystal Lake were analyzed using the Orbeco-Hellige Portable Turbidimeter (Model 966) to determine the turbidity in the samples.

Additionally, the samples were tested for *E. Coli* two times to see what biological effect the *schmutzdecke* had on the incoming water.

Mapping Crystal Lake

Using the Sea Cloud II, depth measurements were taken around the lake using a meter stick and a GPS device. These data points were compiled and sent to Dan Broman, an island engineer, who analyzed the data in ArcGIS in order to create an accurate image of Crystal Lake

Results and Analysis

Testing and Data Collection

The main characteristic which was analyzed was the turbidity of the two effluents relative to the turbidity of Crystal Lake water. The turbidity levels in Crystal Lake, Sand A, and Sand B over three weeks of testing are shown below:

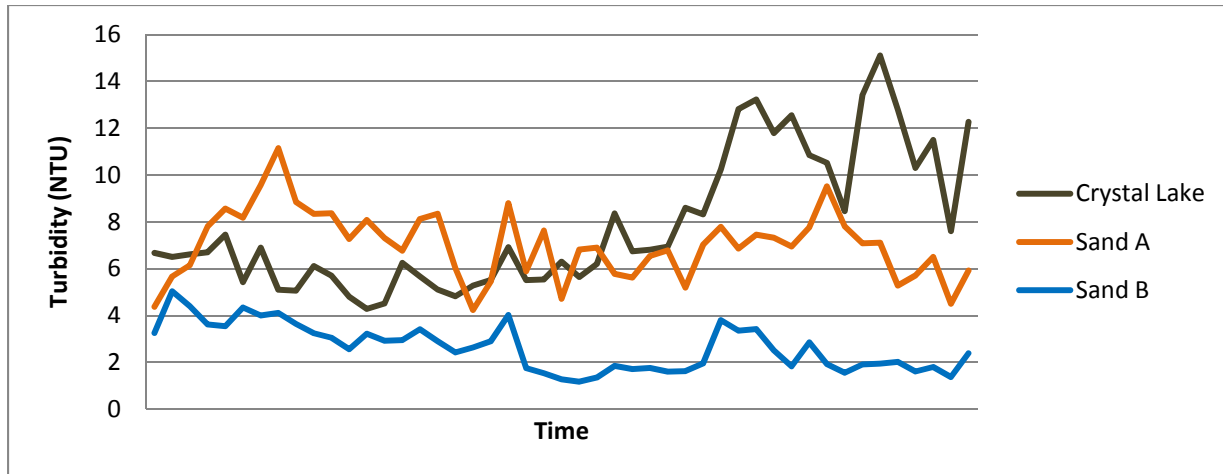

Figure 3.5: Turbidity results over the three week sampling period.

Initially, both slow sand filters showed high turbidity, with Sand A actually adding turbidity to the water. This is most likely due to the fact that the sand was not pre-cleaned. Additionally, during the first couple weeks of testing the *schmutzdecke* is not yet fully formed. However, over time, both sands started to show improvement. While Sand A took longer to show improvement from Crystal Lake turbidity levels, Sand B's effluent turbidity was consistently below that of Crystal Lake. Additionally, when Crystal Lake's turbidity spiked, the turbidity of both sands remained relatively constant. These are reassuring results, implying that the filters can withstand changes in influent turbidity.

In overall turbidity removal, Sand B clearly out-performs Sand A, showing much lower effluent turbidity levels.

Looking at the pC^* values over the same three week period for both sands can give more insight into their performance.

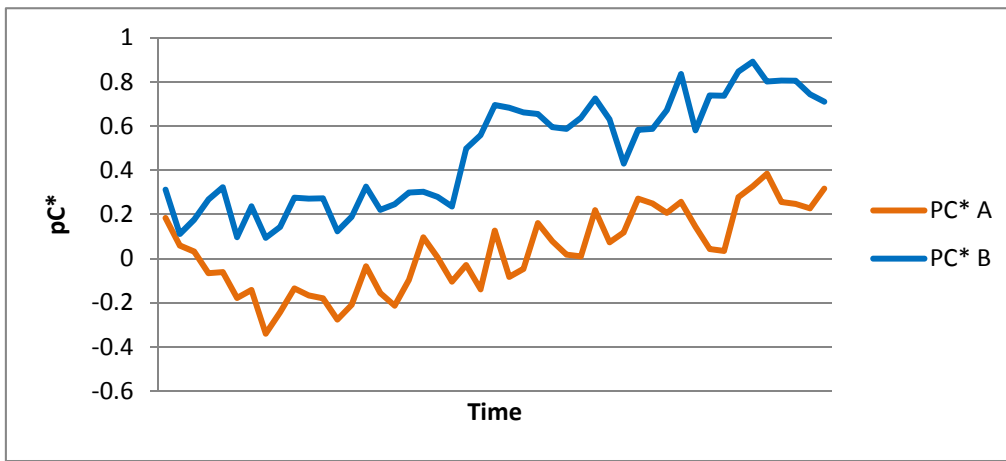

Figure 3.612: pC* performance

While Sand A’s pC* initially dipped below 0, both sands generally had increasing pC* throughout the experiment which is encouraging. Again, Sand B greatly outperformed Sand A, ending with a pC* value of about 0.8 as opposed to 0.3 for Sand B.

Crystal Lake water has high levels of E. coli. For this reason, two tests were done to determine the filters’ ability to remove E. coli. The results are shown below in **Table 3.1** and **Table 3.2**.

Table 3.1: E. Coli test results from 6/30/11

Source	Positive E. Coli Wells
Crystal Lake	51
Sand A	50
Sand B	28

Table 3.26: E. Coli test results from 7/6/11

Source	Positive E. Coli Wells
Crystal Lake	51
Sand A	51
Sand B	2

The filter containing Sand A did not remove E. Coli while the filter containing Sand B was able to remove nearly all the E. Coli in the test done in July. Additionally, Sand B’s ability to remove E. Coli increased between the two tests. This could be attributed to the fact that later in the experiment the *schmutzdecke* was better developed.

Though neither sand reaches the desired turbidity of below 1 NTU or the desired pC* range between 1 and 1.5, Sand B began to approach these levels and showed constant improvement, while also removing E. Coli. Furthermore, this filtered water is used only to recharge the well and not for drinking, so the slightly higher turbidity values would most likely be improved by the natural ground filtration.

While the procedure was effective for comparing the two sand types, future adjustments could increase turbidity removal.

Filter Problems

One problem, identified by Robin Collins from the University of New Hampshire, is related to the gravel support bed. While some gravel is better than none, the gravel should be sized according to the sand diameter. Specifically, a supporting layer of gravel should be no more than four times the mean diameter of what it is supporting. So, instead of using one layer of gravel, the filter should be designed to have multiple layers of gravel, built up from the bottom and getting closer and closer in size to the mean diameter of the sand. For the pilot test, each layer should be about 1-2 inches thick, creating a total of 4-5 inches of gravel. In a full scale filter, this could be doubled or tripled for a total 8-15 inches of gravel. Since the filter did not use this technique of building up layers, some sand may have made it through the gravel and into the filtered water.

The trash bins used for the structure of the filters posed a problem that was quickly noticed. Since the bottoms were not flat. The bins had a raised portion in the center, which would force filtered water to the outer ring.



Figure 3.9: Geometry of the trash bin's bottom.

This likely kept water from flowing directly down through the sand. It also forced water to be collected from the side of the bin, since it was the lowest area. Ideally, one hole would have been drilled in the center of the bin so that the water could follow the path of least resistance down through entire sand column. Collecting under the entire column would also help ensure that we obtained a more even sample of the filtered water.

Robin Collins also suggested that all materials going into the filter be washed. While the gravel was cleaned before being placed in the garbage cans, the sand was not. This may have caused elevated turbidity levels since it can take years for all the dirt to be washed off the sand.

One of the biggest challenges with the design was determining and controlling the flow rate of the filter. After speaking with Robin Collins, it became clear that there were too many effluent holes which made it difficult to lower or adjust the flow rate. Ideally, the flow rate would be kept constant at the value calculated from the loading rate and total surface area of the sand. However, since the pilot filter had such a small surface area, our calculated flow rates were extremely small, making them difficult to manage without some type of flow control valve. Since the flow was nowhere near constant, the beds ran dry a few times, potentially harming the *schmutzdecke*.

Distributing the influent over the sand surface was also a problem. Before water accumulation began, which acts to protect the sand surface from the incoming water, the inflow would often dig small holes into the sand bed. This was another sign that the flow rate was too large. This effect could have been reduced if the flow was less concentrated. The original design consisted of the hose emptying directly onto a radial flow diverter plate in the sand. Later a PVC pipe was installed with holes drilled in it to help dispense the water over a greater area. While this was an improvement, it was still not able to distribute water over the entire surface.

Collection of the filtered water was another area of difficulty. The collecting trays were initially uncovered, leaving them exposed to the elements. They also ran the risk of catching unfiltered water from above, which could drip into the trays. This became a serious problem when the flow rate unexpectedly increased, causing the unfiltered water to overflow the filter and flow into the collecting tray. Eventually, an overflow line was added to address this problem but the trays were still susceptible to leaking water from the hose. Although a plastic tarp was added to cover these trays, Robin Collins later mentioned that they should have been protected from heat and sunlight as well. This turned out to be correct, as we saw algae growing in our collecting trays towards the end of the experiment.

Finding a completely flat surface for the filters to rest was another challenge. Both filters were slightly tilted, preventing the natural flow down through the sand and preventing the entire filter column from being utilized.

Mapping Crystal Lake

Using GIS, the data points corresponding to Crystal Lake depth were mapped creating a topographic profile of the lake.



Figure 3.10: GIS generated profile of Crystal Lake Depth

An estimated volume of $60,176 \text{ ft}^3$ was calculated. This is a 37% increase from the volume calculated last year.

Recommendations

Filter Design Solutions

After analyzing the problems of the pilot test, design solutions that can improve results were investigated.

One simple solution to lower the initial effluent turbidity is to wash all materials before placing them in the filter. The filter should also be backwashed before beginning filtration. This process consists of running water from the bottom of the filter up until the sand is saturated, which helps to remove any air pockets in the sand or gravel. It is a one-time procedure that improves performance by minimizing the space between the sand grains.

The total sand bed height should also be taller. The current filters have less than two feet of sand while an ideal filter should contain at least three. Though the most important part of the filter is the top few inches, increasing the height of the sand column will improve the filtration.

As previously mentioned, an overflow pipe should be added to address the inconsistent flow from the siphon. This pipe would be located toward the top of the filter and would carry excess water out of the system. This would prevent the system from overflowing; however, the overflow water would have to be released far enough away from the filter that it would not enter the well's watershed.

To address the problem of water flowing down the sides of the filter and possibly bypassing the majority of the sand, water should be collected on the bottom of the bin, as opposed to only along the outer rim. This would prevent the outside of the bin from being the path of least

resistance, as in the pilot filters. PVC piping with holes drilled in could collect the water at the bottom of the filter. This manifold would be connected to the outlet pipe at the bottom of the filter.

To better divert the inflow over the entire surface of the sand, a manifold of PVC piping could be placed over the top of the filter, as opposed to letting the water trickle out of one pipe as in the pilot design.

General Design Concepts

Below are factors that need to be considered in using a slow sand filter on the island, independent of the filter design.

Sand Size

The grain size of the sand is the most important factor in turbidity removal as seen through the difference in turbidity values between Sand A and Sand B. As stated above, the two sands used in the pilot tests had very different grain sizes and uniformities. Although pC* ranges didn't reach the recommended values of 1-1.5 for either of the sands, Sand B performed significantly better than Sand A. While Sand B would likely be suitable for any design implemented on Appledore Island, some of the turbidity spikes are concerning. Recommendations generally suggest using a sand grain size between .15 and .35 mm (Tech Brief, a national drinking water clearinghouse fact sheet. http://www.nesc.wvu.edu/ndwc/pdf/OT/TB/TB14_slowsand.pdf). Sand B's grain size is just out of this range at .425-.46 mm. A smaller sand grain size would capture more particles in the water as there is less space between sand grains. This would lower turbidity and also help to decrease the ripening time of the filter. One potential disadvantage of using a smaller sand grain size is that the top layer of sand would need to be raked more often since the pores of the sand would be smaller and would clog faster.

Size of Filter

Another important design factor is how to size the filters, which is governed by the flow rate from the siphon. The head which drives the siphon flow is a fixed value, defined by the difference in height between Crystal Lake and the well. Currently, the volumetric flow rate is about 4 gallons per minute. Using this flow rate, and the loading rate for the sand (generally .05 gal/min/ft²), the surface area necessary for the filters is:

$$4 \frac{\text{gal}}{\text{min}} \div .05 \frac{\text{gal}}{\text{min} * \text{ft}^2} = 80 \text{ ft}^2$$

This means that the total surface area of the sand filters must add up to 80 ft².

Four ways to deal with this large surface area will be discussed:

1. Sizing the filters to meet the requirement
2. Changing the flow rate into the system from Crystal Lake
3. Using a pre-filter holding tank

4. Allowing the water to overflow smaller sized filters and subsequently removing it from the system

Option 1

If the flow rate is left as is and 80 ft² of surface area is required, there are a couple options. These are: to use the two large existing drums, use bins similar in size to those used for the pilot test, or to buy or construct new containers.

The number of filters required for each option can be seen below:

Table 3.3: Filter Options

Material	Diameter (ft)	Height (ft)	Surface Area (ft ²)	Volume (gal)	Surface Area Required (ft ²)	Number Needed	Total Cost (\$)
Drums	5.04	6.08	19.97	908.59	80	4	Only have 2
Bins	1.88	2.63	2.76	44.00	80	29	1885.00
New Option(1)	5.33	6.67	20.00	1000.00	80	4	2756.00
New Option(2)	7.25	5.58	41.28	1550.00	80	2	1444.00
New Option(3)	10.00	7.25	78.54	4259.00	80	1	5366.00

From **Table 3.1**, it's clear why the three other options, which deal with changing the flow rate into the filters, should be strongly considered. Leaving the total filtered surface area at 80 ft² requires a great deal of filter area and, subsequently, a large cost.

The “New Options” presented above represent just a few of the many different options in buying or constructing new filters. However, there are high costs associated with these options. The other options are using cheaper material such as trash bins, or using what is already on the island; there are problems with both. For instance, if trash bins or similar sized filters were to be used, a large number of individual filters would be required. This creates multiple problems, such as controlling the small flow rates that would exist after splitting the siphon flow, questionable durability of these smaller scale filters, or the extra piping and connections that would be needed. For the drums, the obvious problem is that we only have two. Also, the drums will be harder to move, fill, and maintain.

Option 2

Another option to consider is changing the flow rate into the system from Crystal Lake, which will reduce the required surface area of the filters. This can be done in two ways. A valve or similar restricting device could be used to decrease the flow or flow could be diverted out of the system and deposited somewhere else.

Using a flow restricting device is a good approach because it does not waste any of the valuable water in Crystal Lake. It would also provide some control over the system. The concern with this option is keeping the siphon functioning. Restricting its flow may prevent it from working, or require frequent re-priming.

The other option is to divert a portion of the flow. This would consist of a split in the siphon line which would carry a desired portion of the flow out of the filtration system. This raises the similar problem of keeping the siphon intact. If we decrease the flow too much in either of these lines, air could enter the siphon which may shut it down. Another concern is where to release the water once it is tapped out of the system.

Option 3

An option that could reduce the required filter surface area and keep the original siphon flow rate is a pre-filter holding tank for the Crystal Lake water. A pre-filter holding tank would act as a large reservoir into which the Crystal Lake water would flow and be stored before going into the filters.

In this way, the flow rate into the filters can be better controlled by controlling the flow rate out of the reservoir. Also, Crystal Lake water would not be wasted, nor would the flow out of the siphon be jeopardized. The tank would also allow for some settling of suspended particles in the water. During this time, sedimentation, particle agglomeration, and oxidation occur which improves the quality of the water. This option would also allow Crystal Lake water to be collected early in the season at low turbidities. Ian Hewson, a Shoals Microbiologist, believes that storing the water in a holding tank would have no negative effect on the microbiology of the water as long as the tank is under cover, out of the light, and aerated or exposed to oxygen. Under these conditions, algae and cyanobacteria would die and all other organisms would either die or not replicate. Ian also stated that the reason for the significant turbidity spike toward the end of the season is the increase in algae throughout Crystal Lake. High algae levels would be troublesome to a filter because it can clog the sand pores. A holding tank could potentially lower the turbidity and increase performance in the filter since slow sand filters are generally only effective for water with a turbidity lower than 10 NTU.

However, there are problems with this option as well. One would be the size of such a reservoir. To get an idea of the size of the tank, the quantity of water that can be withdrawn from the lake over the span of two weeks is calculated:

$$4 \frac{\text{gal}}{\text{min}} \cdot 60 \frac{\text{min}}{\text{hr}} \cdot 24 \frac{\text{hr}}{\text{day}} \cdot 14 \text{ days} = 80,640 \text{ gallons}$$

A tank this large would not be a good option, as it would be extremely expensive and take up a lot of space. However, if the siphon was not running the entire time the tank could be sized down based on how many times it is filled it up in a season. Say, for example, the siphon is restarted once a week. In this way, the size of the reservoir could be further reduced:

$$\frac{80,640}{2} = 40,320 \text{ gallons every week}$$

This would still be a relatively large and expensive tank and would require frequent restarting of the siphon. This number could also be further reduced if the reservoir were to be re-filled more often. Tanks of such size could not be found and would most likely have to be specially made, but below are large tanks that could be used if the reservoir were to be refilled more often:

Table 3.4: Tank sizes and costs.

Diameter (ft)	Height (ft)	Volume (gal)	Total Cost
10	9.75	5700	\$ 6,770.00
10	11.83	6800	\$ 7,858.00
11.75	13.33	10000	\$ 6,641.00

A more practical option is to utilize this system with less water by restricting or diverting the flow, since in the past three years the island has used at most 40,000 gallons of water from the reverse osmosis machine.

Another concern with the reservoir would be where to place the outlet valve for the water to exit. The turbidity would be higher toward the bottom of the tank since the particles would settle over time. One cannot simply withdraw water off the top since, as previously mentioned, this reservoir would initially be filled and then emptied over time. A height where low turbidity water can be drawn would need to be determined.

Option 4

The last approach is similar to diverting the flow from the lake, except that it would divert as little water as possible. This could be done by allowing the entire flow from the lake to enter the filters and having any excess water exit the system through an overflow line. However, as before, it is not clear what to do with the water once it has been diverted. Also, there is a risk of disrupting the sand surface with such a large initial flow. Once a layer of water is developed above the sand this would not be a problem, yet initially, a large inflow of water striking the sand surface could dig holes and make the surface uneven and difficult for a *schmutzdecke* to form.

Location

In placing the slow sand filters, there are a few factors to be considered: how level the land is, the ability to control flow, sufficient space for construction, and compatibility of the filter system with the current infrastructure. In looking at these design restrictions, there are two options: near the well or in the flat area north of the Kiggins' Commons' deck.

Putting the filters in front of the Commons' deck was originally brought up by Ross Hansen, who noticed this unused and exceptionally flat area. Having the filters here may solve the problem of where to dump any excess water from Crystal Lake, since it could be piped to the low area just north of this location. If the filters were to be located at the well, it would have to be determined how far the well's water shed stretches before dumping excess Crystal Lake water, unless it were dumped into the ocean. The Kiggins location is also most likely the largest available flat area that could be used for the filters. If they were constructed near the well, land would most likely have to be flattened before setting up the filters. However, the Kiggins

location brings about problems as well. First of all, it creates a stop in the flow of water, which eventually needs to make it down to the well. It would be difficult to siphon to the Commons since it is closer to the elevation of Crystal Lake. There is a 13 foot difference in height between these two locations, as opposed to 19 feet between the lake and the well. Stopping the flow here would also require another siphon to get the water down to the well, increasing the chance of a siphon failure. The water exiting the filter would also have a low flow rate making it difficult for the water to flow to the well. Having the filter in a separate location from the well would also prevent the entire filtration infrastructure from being in one centralized and easily accessible location.

Ripening Water

Another issue to take into consideration is what to do with the water used to ripen the *schmutzdecke*. At the beginning of the season it will take 10-20 days for the *schmutzdecke* to fully form, and for the quality of the water exiting the filter to be high enough to empty near the well. Therefore, water used during this ripening period would have to be released at a safe distance from the well. An analysis of the island's watershed and ecosystems should be conducted in order to pick a location to dump excess ripening water without contaminating the well or harming the ecosystem.

Distribution of Filtered Water

The last step of the filtration process is to dispense the filtered water around the well so that it can slowly seep through the ground and recharge the well. This must be done in a large enough area around the well to ensure that no one area is overloaded with water, which would then flow down too quickly and not get filtered. This means that the filters need to be designed in such a way that the effluent can be effectively distributed around the well. This would most likely be done in the form of a pipe or tube manifold in a specified radius around the well. Thus, the filters must either be effectively placed around the well so that they evenly distribute the water, or their outflow rates must be large enough that the water can be carried through the manifold and cover the entire area.

Pumps

Using a pump in the filtration system is an extremely important consideration for the design. While this addition would be extremely expensive, both in capital cost and by adding to the electricity load of the island, it could solve many problems in the system and make it run more consistently. A pump could be used to regulate a number of the different flow rates in the system, which could help to solve many of the problems listed above. This would also make it significantly easier to control how much water is drawn from Crystal Lake and it would ensure that the water is readily available unlike the siphon.

Proposed Filter Design

A new filter design is proposed below which solves many of the problems seen in the pilot design. This design is independent of the system selected.

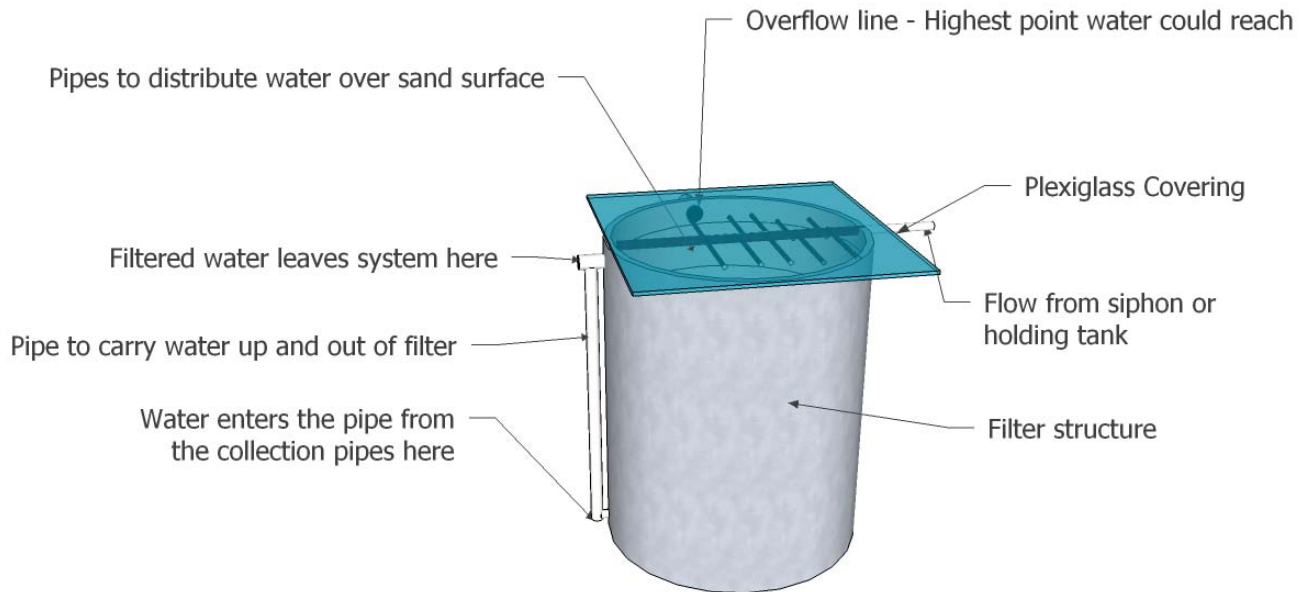

Figure 3.11: New filter design

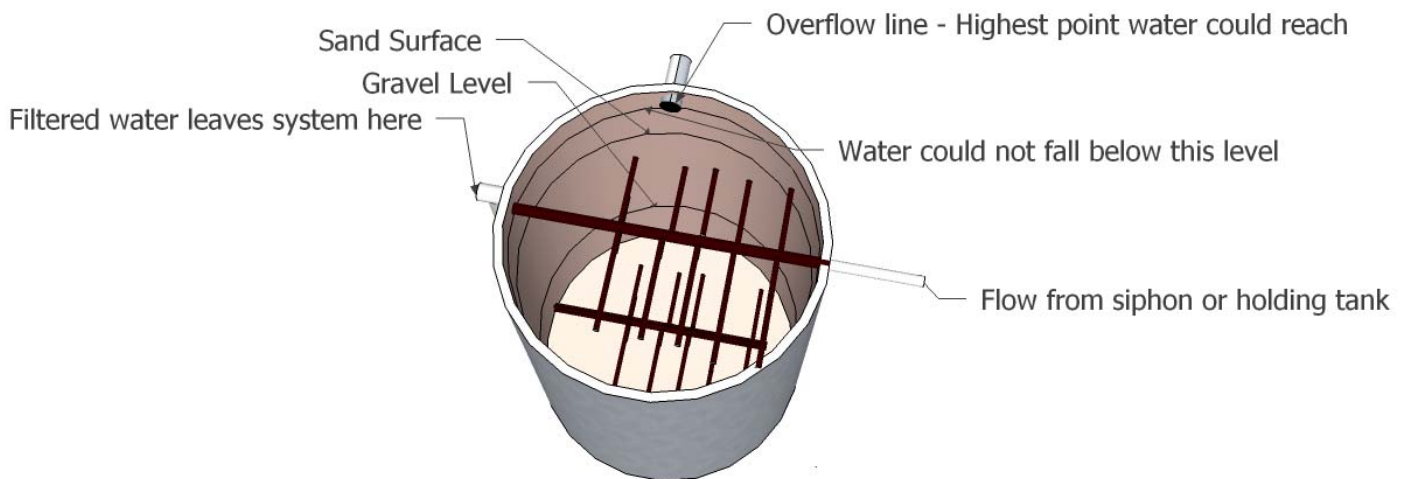

Figure 3.12: Inside of filter design

The biggest improvement in this filter from the original pilot design is the PVC pipe leading from the bottom to a few inches above the sand surface, along the outside of the filter. This design, suggested by Robin Collins, helps to solve many of the problems related to the inconsistent flow of influent water. Instead of having the effluent water leave the system at the

bottom of the filter, it would first flow up to about an inch above the sand. At this height, the water could then be collected. Since the filter is gravity driven, the water would be forced up this pipe by pressure due to the weight of water, sand, and gravel in the filter, as well as the atmospheric pressure on the surface. The only pressure acting at the collection point would be atmospheric. According to Bernoulli's equation, we know that the pressure within the tube must be constant. Thus, since both ends are open to atmospheric pressure, we can adjust this pressure balance of water in the filter to control the amount of supernatant water. So, as long as this collection point is above the sand surface, the sand will remain saturated. If the inflow were to stop or slow down to a point where the water level drops below this collection point, water will no longer flow out of the filter, keeping the sand saturated for a longer period of time, and keeping the *schmutzdecke* alive. This design would account for the inconsistent flow from the siphon, which was a major hurdle in testing.

This design would also collect the filtered water in a more efficient way than the previous one. Instead of having it flow out the side of the filter through holes, the water would be collected through PVC pipes laid across the bottom of the filter. As previously described, the pipes would have small holes drilled in them through which the filtered water would be forced to flow through. This connection of pipes would then lead to the pipe going up the outside of the filter. The PVC would be covered in layered gravel followed by the sand. To distribute the water over the sand evenly, a similar PVC section, as described earlier, would be constructed.

System Design Solutions

Using the Drums

Using the existing drums as filters would be resourceful and cost effective for SML. It would allow Shoals to avoid the extra cost in buying new materials and would make use of what may otherwise be trash. There are two options in using the drums: keeping them as is and creating a filter out of each, or cutting them in half, making a total of four filters.

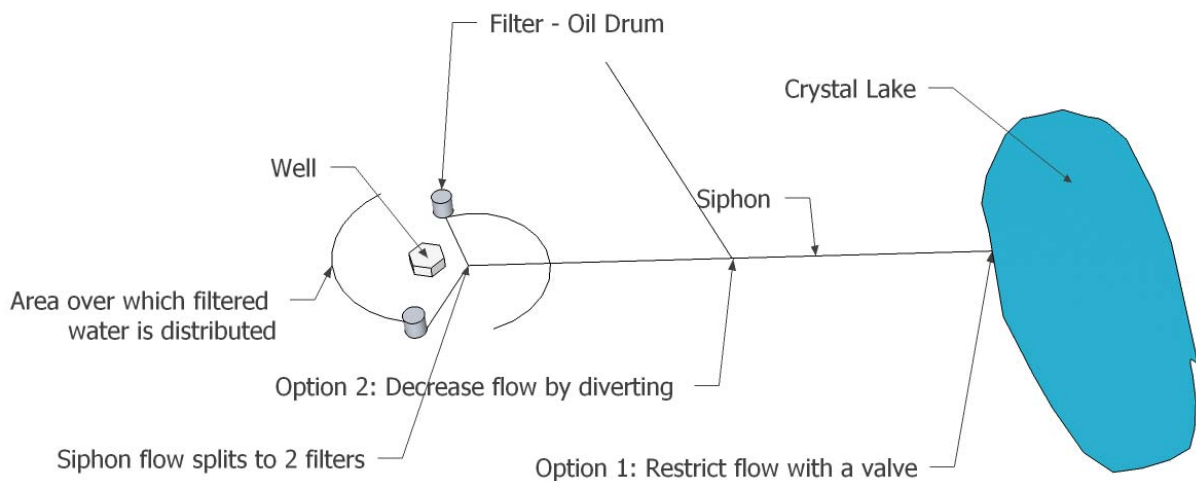

Figure 3.13: Diagram of a possible set up with the two drums.

If used as is, the drum filters would be a little over six feet tall, having more than enough height to hold the six inches of gravel and recommended three feet of sand. The additional height could be taken advantage of as extra space for the accumulation of water on top of the sand. In this way, the filters would have more protection against running dry since they would take a longer time to drain. They would have a total filter area of approximately 40 square feet, which would only cover half of the flow rate from Crystal Lake. To solve this problem, the flow could either be diverted into another pipe or a valve could be used to restrict the flow, as mentioned above. If diverted, half of the total flow would still be used and the siphon would have less chance of failing. We would also avoid having to restart the siphon multiple times throughout the season since there would be no pre-filter holding tank in which the gravity driven flow would stop. In addition, there would be no need for a device to control the flow at the entrance to the filters since they would be sized according to the siphon's flow. To distribute the flow evenly around the well, the two filters' effluents could be split, each covering half of the area. A pipe or tube would be laid in a semicircle extending from each filter, with small holes drilled in it to let the water slowly drain out around the well. Since the flow would only be split in two, there should be enough head in each line to reach the ends.

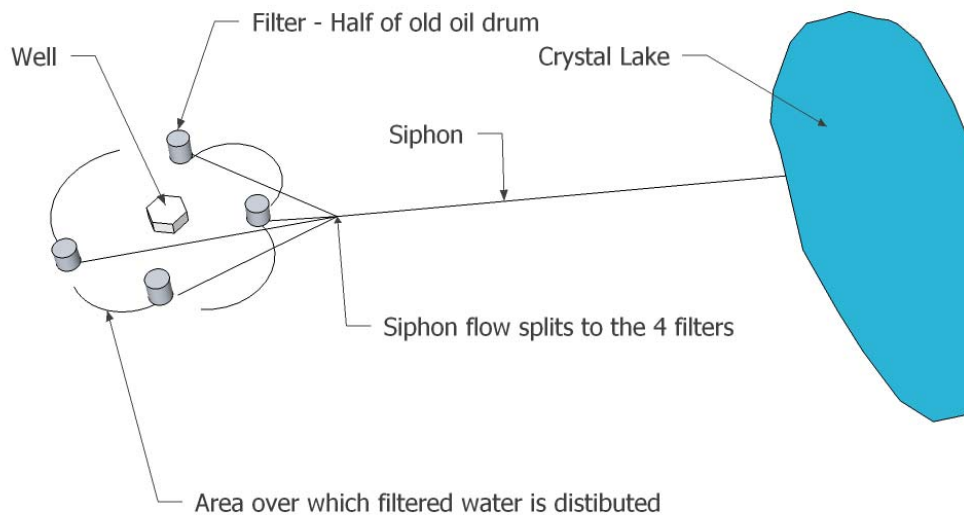

Figure 3.14: Diagram of a possible set up making 4 filters out of the drums.

Cutting the drums in half to create four may be a better option, as it would allow almost the entire flow from Crystal Lake to be utilized. No water would have to be diverted or wasted, and the flow could be left as is, ensuring the siphon would stay intact. The system would then consist of four, approximately 20 square foot filters, meeting the 80 square foot requirement determined from the siphon flow rate and the sand's loading rate. Again, this system would require no device to control the flow at the entrance into the filters, which was one of the hardest problems to overcome in the pilot design. While the two bottomless halves would have to be attached to a solid base, it would also be easier to construct the drainage manifold for these halves since the manifold could be placed before being attached to the enclosing drum. However, these filters would be approximately three feet tall which would not allow for three feet of sand as in the previous design. If the recommended six inches of gravel was used, these filters would have approximately two feet of sand. However, the pilot filters only had one and a half feet of sand yet still showed good filtration. Furthermore, Robin Collins said this amount of sand was acceptable, being on the lower end of the range for slow sand filters. Using the same strategy as above, the filters could be set up around the well, each covering one fourth of the area to evenly distribute the effluent.

Both of these options present a straightforward approach to the filtration system, allowing the water to flow straight from the lake, to the filters, to the well area, without stopping the flow. They also require a minimum of piping and complexity. Furthermore, they avoid the extra cost of buying tanks for the sand filters or a pre-filter reservoir.

Using a Pre-Filter Holding Tank

Another option is to use the drums as filters as mentioned above, but with the influent water entering the filters from a holding tank instead of the siphon to control flow and lower turbidity.

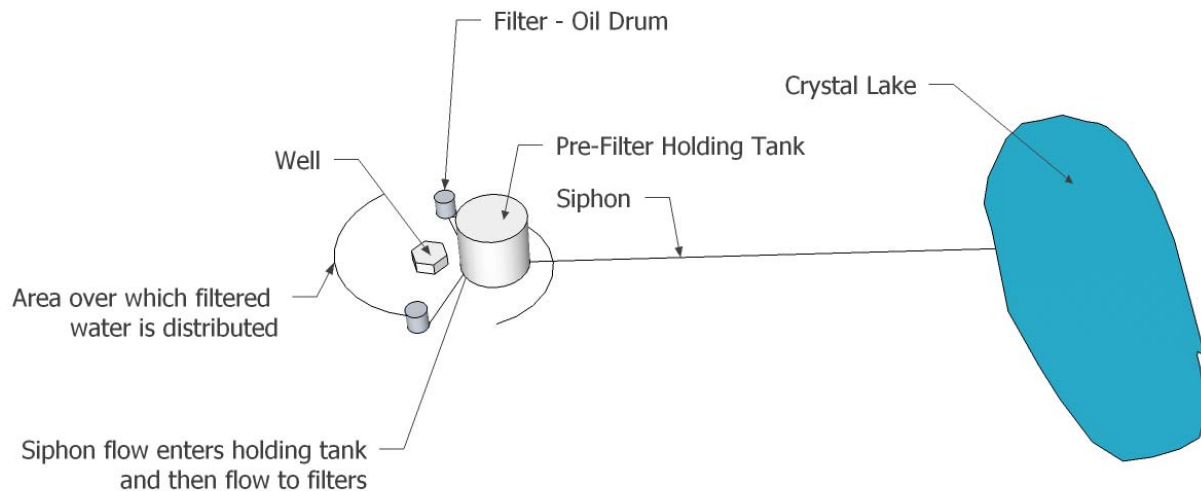

Figure 3.15: Diagram of possible set up with a pre-filter holding tank

The elevation of Crystal Lake is 56 feet. Elevations around the well vary from 34 to 38 feet, creating a difference of 18 to 22 feet. In this proposed design, water would be siphoned into a holding tank which would sit at an elevation of 38 feet. All of the siphon's flow would be used to fill the tank and the siphon would be turned off once the tank was filled to capacity. The water in the holding tank would then flow into the filters, which would sit at an elevation of 34 feet. The difference in height between the holding tank and filter allow water to flow from a valve at the bottom of the holding tank toward the top of the filter. There would also be a sludge drain toward the bottom of the tank that would be drained periodically when the water level is low to remove solids that have accumulated from sedimentation. The filtered water would flow through a hose or PVC pipe to be distributed in the area 50 feet from the well.

This design is beneficial because the holding tank would improve the quality of the water before it enters the filters as discussed previously. This is especially important toward the middle and end of the summer when the turbidity of Crystal Lake surpasses 10 NTU, which is generally considered the acceptable filtration range. If the 10,000 gallon storage tank was utilized it could be filled in early July right before turbidity spikes and last for most of the rest of the season. It would also be significantly easier to maintain a flow rate using a holding tank as opposed to the siphon which lacks a constant flow rate. The main disadvantages to this system are that a holding tank would need to be purchased and transported and the siphon would need to be primed multiple times in the season if the siphon doesn't hold when the valve is shut off.

Additional Options

One option to consider if turbidity or E. Coli counts are too high as the season progresses is the addition of chemicals. Aluminum sulfate, $Al_2(SO_4)_3$ (alum), causes the water's suspended solids to stick together and coagulate, making the process of filtration more effective by decreasing ripening time. While organisms in the *schmutzdecke* help, physical and chemical particle removal extracts most of the turbidity. Alum also shows potential to reduce E. Coli concentrations. Alum is a naturally occurring relatively inexpensive chemical. However, with this process comes the need for constant monitoring of the system, as well as the cost of shipping alum out to the island.

By looking at the logs for the reverse osmosis machine, we found that in past years such as 2007 the island has needed up to 120,000 gallons of water from the machine. Based on the slow sand filter flow rates and uncertainty about how much water actually will flow from the surface and into the well, it may be impractical to build enough slow sand filters to supply 120,000 gallons of water to the well each year. Other filtration options with higher flow rates may need to be considered such as rapid sand filtration if the goal is to make the reverse osmosis machine completely obsolete. However, in the past three years 40,000 gallons of water or less has been used by the reverse osmosis machine. This quantity of water can certainly be supplied by slow sand filtration.

Finally, it is recommended that SML update their permit from the state of Maine to withdraw a greater volume of water from Crystal Lake each year, based on the new depth profile.

The Research Vessel John B Heiser Performance Measurements

Background

The John B Heiser is a 36' aluminum boat owned by Shoals Marine Lab. Its propulsion system is a diesel engine driving a water jet drive. The original engine was replaced this winter. Previous interns determined that boat trips are a large expense for the island and suggested that they be further investigated. Working with the captains, this year's interns sought to increase the efficiency of the boat, thus reducing costs.

Objective

Determine a method of measuring fuel consumption at fixed speeds and RPMs with various loads. Using this information, determine the optimum speeds for fuel efficiency with various loads on board.

Procedure

Through research and conversations with the captains, it was determined what types of data would be most beneficial to analyze. The engine's displayed functions were investigated and found to provide enough information to calculate fuel consumption. To collect data, log sheets listing all required parameters were created. Captains were asked to fill them out as often as possible. A sample log sheet can be seen below:

Date:	6/19	RPM	gal/hr	Speed (Kn)	Engine Load (%)
# of Ppl:	16	2150			
Direction:	NNW	2175			
Duration:	40 mins	2200			
Distance to Destination:	8 NM	2225			
Tide:	Rising	2250			
Sea/Wind Conditions:	NW 5-10 Kn	2275			
Luggage:		2300			
		2325			
		2350			
		2375			
		2400	14	11.3	51
		2425			

			2450			
			2475			
			2500	15	12.3	57
			2525			
			2550			
			2575			
			2600	17	14.1	66
			2625			
			2650	18	15.3	69
			2675			
			2700			
			2725			
			2750			
			2775			
			2800			

Figure 4.1: Sample log sheet

As seen above, few data points are filled in. The majority of log sheets only contained information for one or two different RPM levels. The largest challenge with this project was that it required a lot of information to be taken down at varying RPM levels. In practice, the boat is run at fairly constant RPM, making a wide range of data difficult to obtain.

Results and Analysis

After collecting the data from the boat logs, the average gal/hr, speed, and engine load was determined for each RPM that had data. Using this data, the average nautical miles per gallon spent at each RPM was found:

$$\eta_{fuel} = S_{JBH} \cdot r_{fuel} \quad (4.1)$$

Where

η_{fuel} represents fuel efficiency (NM/gallon)

S_{JBH} represents the speed in knots of the J.B. Heiser Research Vessel (nautical miles per hour)

r_{fuel} represents rate of fuel consumption (hours/gallon)

Initially, the most efficient RPM to run the boat at was determined by looking at this fuel consumption data. Graphing the results for all trips we obtain **Figure 4.1** at the top of the next page.

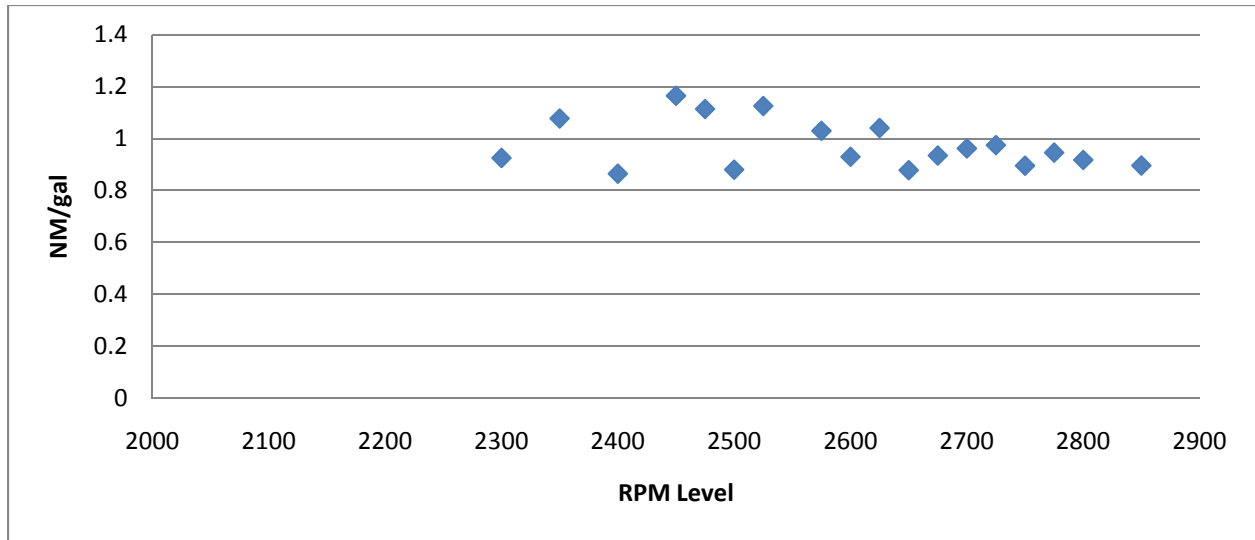

Figure 4.2: NM/gal for All Trips

This graph shows that boat trips that were run in the 2400 – 2550 RPM range displayed nearly 20% greater efficiency. However, these results have a great deal of scatter and don't take into account the weight on the boat at the time of measurement.

For this reason, the data was separated into two categories: trips with light loads and trips with heavy loads. A heavy load was defined as the load on the boat consisting of more than seven people or a boat that was weighed down by luggage or food. The lower resolution of having two bins (e.g. light and heavy) is unfavorable. However, making this separation gives a better understanding of how the boat performed under different circumstances.

Light Loads

Graphing the same results as above for only light loads yields the following **Figure 4.3**:

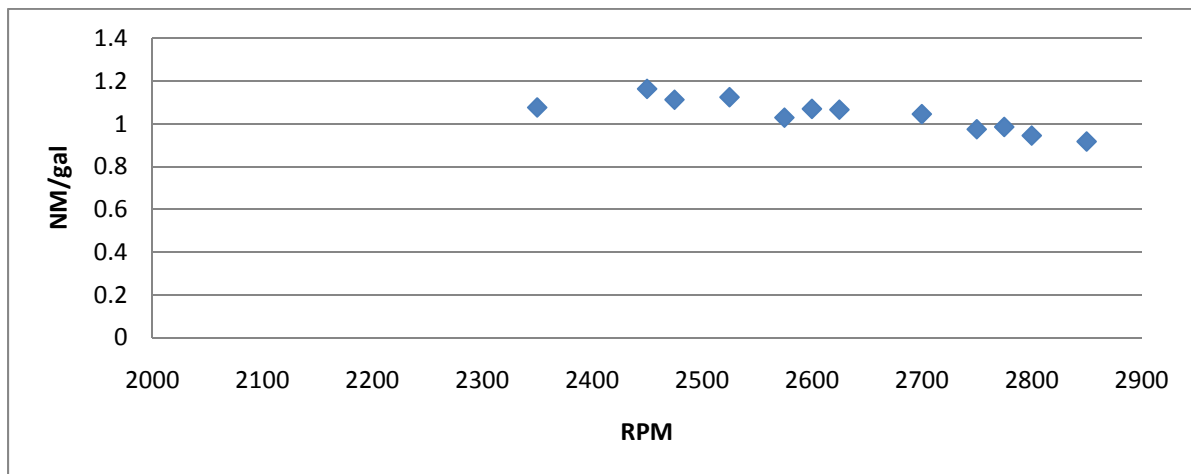

Figure 4.3: NM/Gal for Light Loading Situations.

For light loads, a more systematic relationship exists within the data. There is also less scatter which gives more definitive results. The data shows that running the boat at an RPM level greater than 2550 will decrease fuel efficiency. The peak fuel consumption is similar to that shown before, falling between 2400 and 2550 RPM.

Heavy Loads

Finally, graphing the same parameters for heavy loads results in the following:

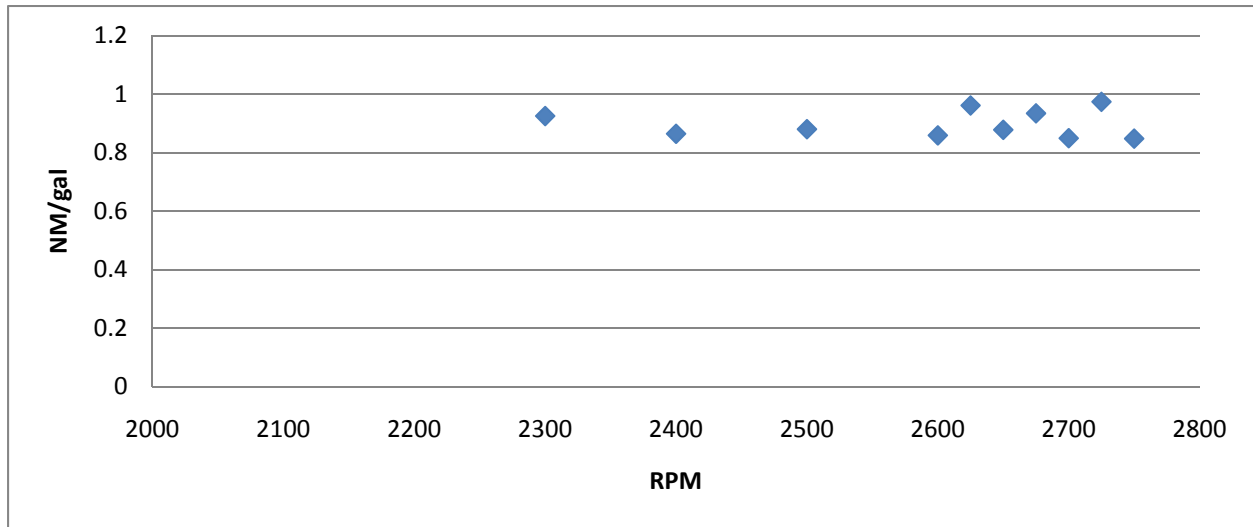

Figure 4.4: NM/gal for Heavy Loads.

Figure 4.4 shows that there is no obvious trend from the data collected for heavy loads. The vessel performs with similar fuel efficiency over the entire range of recorded RPM levels. There is no correlation between engine speed and fuel efficiency for the data set.

Recommendations

To increase fuel efficiency for lighter loads, it is recommended that the J.B. Heiser is run between 2400 and 2550 RPM, and rarely run above 2600 RPM, as this was shown to decrease fuel efficiency.

To truly understand the J.B. Heiser Research Vessel’s performance, more data must be collected. A continuation of the aforementioned data collection may not be sufficient. No analysis was performed on sea or wind conditions as a constraint on fuel efficiency. In addition, the total weight of the vessel and fuel should be determined in order to understand the significance of weight difference between “light” loads and “heavy” loads.

Caterpillar offers data acquisition equipment which would allow the island staff to digitally monitor the boat’s engine over an entire season. Depending on how useful the island staff determines this information to be, this may or may not be a profitable decision.

Additionally, between May 18th and June 27th this year there were nine trips between Appledore Island and Portsmouth that had six passengers or less in both directions. Assuming large amounts of luggage or materials were not on board, these trips can be accomplished next year with the new boat, the Aci Penser, which will be smaller and more fuel efficient.

The Aci Penser was recently acquired by SML from Cornell University. It is a 27' aluminum boat that is suitable for six passengers on board or less since it won't be Coast Guard inspected. While fuel efficiency information is not available on this boat, it is expected that the Aci Penser will be faster than the Kingsbury and more fuel efficient than the Heiser. Using this boat for trips with fewer passengers could save SML a significant amount of fuel.

Shoals Sustainable Systems Awareness

Background

In an effort to become more sustainable, SML installed composting toilets and its first solar water heating system in the new Water Conservation Building this year. Additionally, over the past three years SML has installed a green grid which generates energy from 7.5 kW of PV panels and a 7.5 kW wind turbine. Though the island population generally understands that there are big changes happening to some of the main systems at SML, there is no way for visitors to have a basic understanding of the sustainable efforts taking place.

Objective

Make people aware of the sustainable systems at SML.

Procedure

Composting Toilets

The information and diagrams from the Clivus Multrum website, manufacturer of the composting toilets, were used for the preliminary design. Mike Rosen and Ross Hansen were also consulted to learn more about the Appledore Island system.

Solar Water Heating System

Doug Gerry of Clean Energy Solutions has been the primary architect and installer of SML's solar water heating system. The system he has designed is uniquely created for SML. Information collection for this project was done primarily through meetings with Doug. Doug also gave a technical tour of the solar water heating system while under construction, helping to form a template for the informational poster.

The Green Grid

By adding new installations to a previous flow chart of the green grid, a new graphic suitable for display was created. Additionally, a schematic of the green grid was overlaid on a map of the island.

Results and Analysis

Posters were designed for each area in which SML has made sustainable advances. The posters include all the information considered to be important and appropriate for the SML community audience. However, the images which go along with this information are rather rough and could be improved upon by a person well versed in Adobe Illustrator or another drawing program. The images provided below are meant to be visual tools for the time being and should be further enhanced in displayable versions.

Composting Toilets

In order to estimate the number of gallons of water saved per year with the composting toilets, data from past interns was referenced. The 2009 interns placed charts inside all of the bathrooms for a week in order to estimate how often toilets are flushed. Comparing total flushes with the population log, a rough estimate was generated for how many gallons are flushed per person per day at the Kiggin's bathrooms based on the previous toilets' five gallon flush.

Table 5.1: Average number of flushes per person in the old bathrooms in Kiggin's Commons.

Date	Total Kiggins Flushes	Total Gallons	Population	Gallons/Person
28-Jun	35	175	50	3.5
29-Jun	47	235	57	4.1
30-Jun	49	245	57	4.3
1-Jul	51	255	57	4.5
2-Jul	61	305	57	5.4
3-Jul	47	235	57	4.1
4-Jul	50	250	57	4.4
5-Jul	41	205	60	3.4
			Avg. Gallons/Person/Day	4.2

Using this value of 4.2 gallons/(person·day) in the Kiggin's bathrooms, the 2009 and 2010 population data for the season was used to estimate how many gallons are saved using the new six ounce flush toilets. This results in an average of .04 gal/person/day. Based on this value and population logs, SML saves between 20,000 and 25,000 gallons per year with the composting toilets.

The following figure shows the main features of the composting toilet system. Neponol is a combination of soap and 3-6 ounces of water that comes out of the top of the toilet bowl and moves the waste from the toilet to the composter. This minimizes the use of water when compared to conventional toilet flushing, using 1% of the water that was used in the previous system. A vent is located behind the toilet bowl and air is dragged through the toilet bowl and out of the vent to avoid odor.

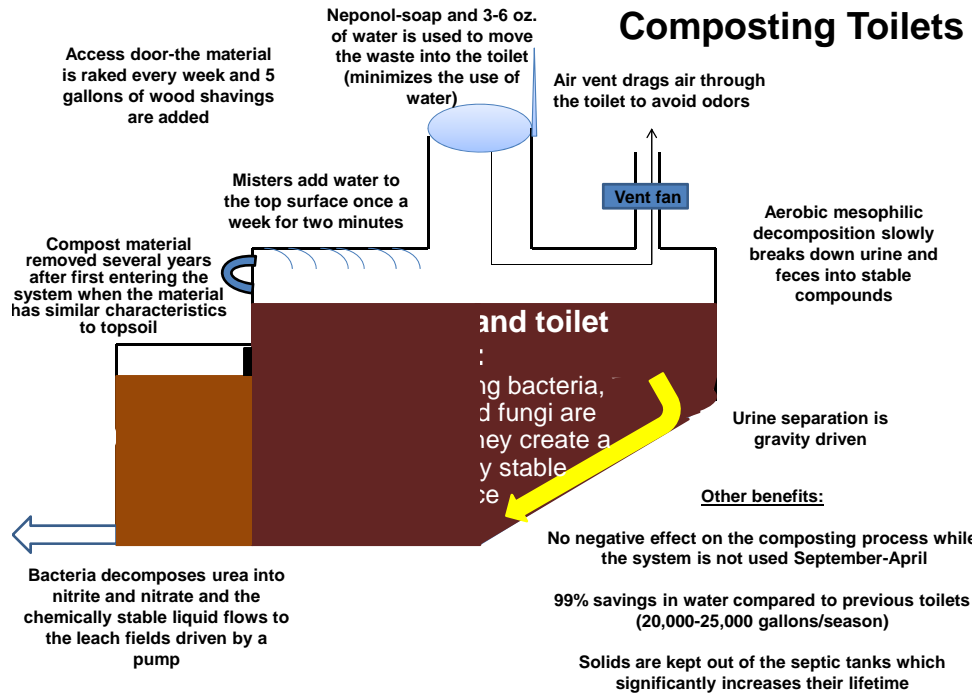

Figure 5.2: General outline of the composting toilets educational poster to be placed outside the Water Conservation Building.

The process of aerobic mesophilic decomposition slowly breaks down the urine and feces inside the composter into stable compounds. Urine separation is gravity driven by the slope of the toilet. Bacteria decompose urea into nitrite and nitrate, and then the chemically stable liquid is pumped to the leach fields. Organisms in the composter include bacteria, actinomycetes, fungi, and arthropods that are added manually. These composting organisms create a more chemically stable substance. The compost material is removed from the access door several years after entering the system, having similar characteristics to topsoil. This system is beneficial to Appledore Island because it minimizes the amount of solids entering the leach fields. Maintenance is also minimal; the material is raked once a week through the access door and five gallons of wood shavings are added each week in addition to two minutes of misting on the top layer.

Solar Water Heating

Solar water heating is a technique of harnessing solar energy for thermal energy. It uses a thermal mass material, or phase change material (PCM) which stores the sun's thermal energy until cooler conditions trigger the release of the stored heat. PCMs are compounds which melt and solidify at precise temperatures and are capable of storing and releasing large amounts of thermal energy, essentially exploiting the latent heat of fusion. Water, stone, concrete, soil and modified soy bean oil are all considered PCMs, though there are more complicated compounds which have extreme melting and freezing points.

The diagram below outlines the basic qualities of SML’s solar water heating system. Though solar collectors can be Evacuated Tubes (ET), SML’s system is made up of ten Flat Plate Collectors which have a selective absorber surface, allowing them to absorb thermal energy from the sun. Flat Plate collectors are the most economically feasible collectors and will outperform ET collectors in spring, summer and fall. This makes them most the most productive option for use during SML’s prime operation.

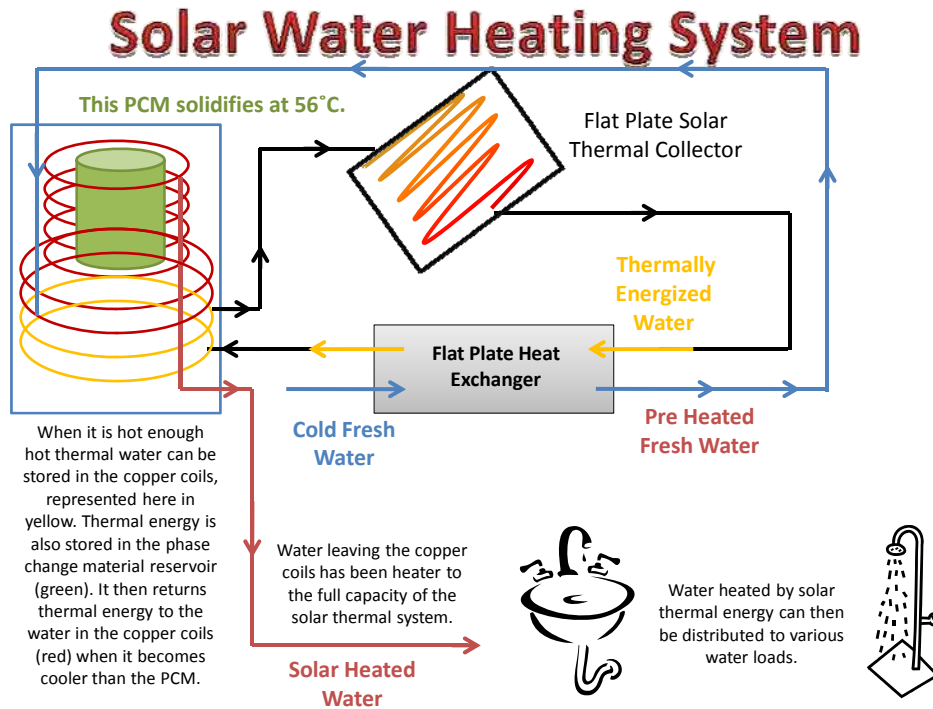

Figure 5.3: General outline of the solar water heating system educational poster to be placed outside the Water Conservation Building.

Water from the solar water heating system will serve the Water Conservation Building, the showers in Kiggins Commons, and the kitchen’s sinks. This system has the capacity to completely replace the previously used method of propane heating.

The Green Grid

Though the green grid is a complex system with numerous devices, the items which would be understood and interesting to the average person have been included in the schematic below.

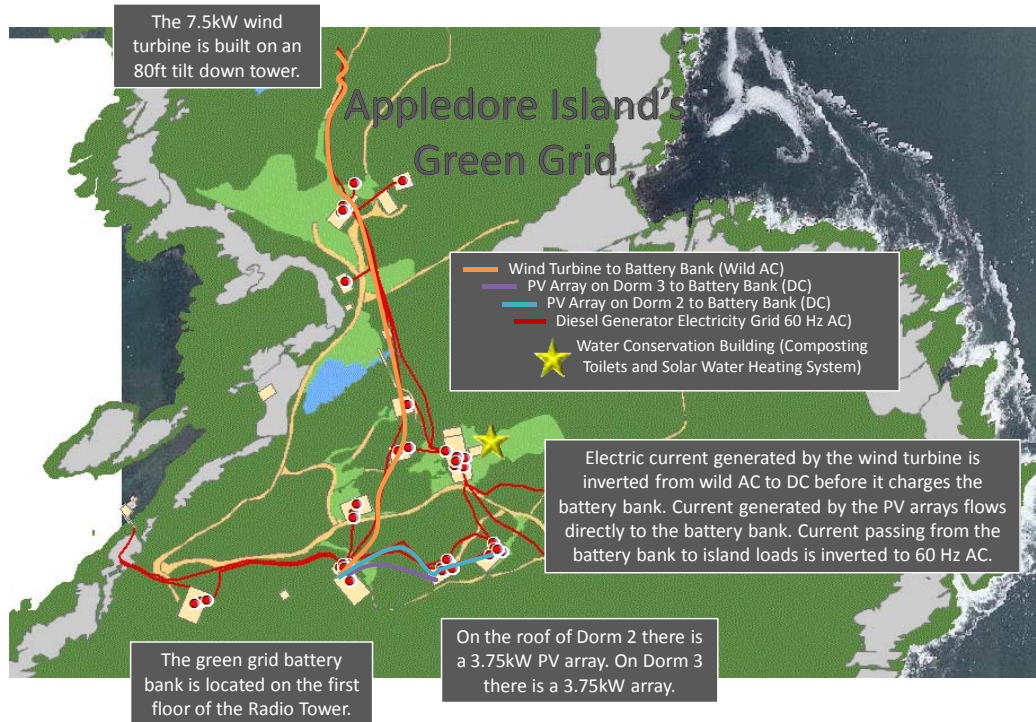

Figure 5.4: Diagram outlining the general details of SML's green grid.

The solar PV panels are monitored and controlled by OutBack Power's inverters, Mate, MX60 and FLEXmax80 while the wind turbine output is currently not monitored. As was mentioned in the Alternative Energy project report, SML is hoping to have each form of alternative energy metered. From this, SML hopes to display the actual output and the green grid's usage of the alternative energy produced in an easy-to-understand manner.

Recommendations

It is recommended that the educational and informative posters with graphics are placed on the Water Conservation Building in between the entrances of the Men's and Women's bathrooms. This location allows everyone who uses the building to read the information. The diagrams provided should be used as a guideline for what should be included in the final posters.

Kiggins Commons Acoustical Improvement

Background

Historically, Kiggins Commons has had undesirable acoustic characteristics. People complained that conversations were hard to hear, and that the room's background noise was distracting. This was due to the Commons' high reverberation time at high frequencies, which left sounds bouncing around walls and into unhappy ears. In 2010, the acoustics of the dining hall were analyzed by the Sustainable Engineering Intern team.

The interns worked to determine the room constant, R , which is a dimensionless measure of sound absorption within an enclosed volume. They were able to make an estimate of this value by measuring sound pressure in the presence and absence of a constant noise source (a ShopVac). From this, the interns estimated an average reverberation time, measured in seconds. This quantity represents the amount of time that it takes for a direct sound to decay 60 decibels (dB).

At volunteer's weekend this year, 60 foam acoustical panels were installed in Kiggin's Commons. Qualitatively, everyone has agreed that the acoustical performance of the room has improved.

Objective

Quantify the acoustical improvement in the dining hall in Kiggin's Commons.

Theory

One of the tools used in the quantitative analysis was a sweep test, which works by playing a noise that begins at a low frequency (63 Hz) and "sweeps" through the human ear's bandwidth, up to 8 kHz. The sweep signal is sent to a reference loudspeaker specifically designed to have a flat frequency response. The speaker is directional – that is, it tends to send sound in a single direction as opposed to a radial delivery of sound. The iPhone's built in microphone records the sweep sound from the speaker and uses the *Audio Tools* application to analyze it.

When the iPhone records the sweep, it calculates a Fast Fourier Transform (FFT) plot, which is essentially a graph showing the amplitude of the sound (volume) versus frequency. The following **Figure 4.1** is a sample FFT plot from one of the testing configurations.

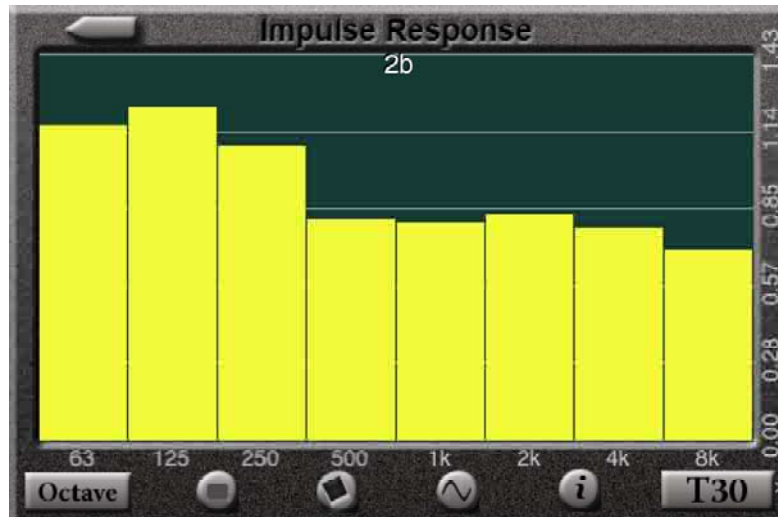

Figure 4.1: Screen shot captured from the *AudioTools* application showing an FFT plot.

From the FFT calculation, *Audio Tools* is able to generate an Energy Time Curve (ETC). This shows Amplitude versus Time, and allows the user to see the time response of the sound, as opposed to the frequency response as above. A sample ETC is shown below in **Figure 4.2**:

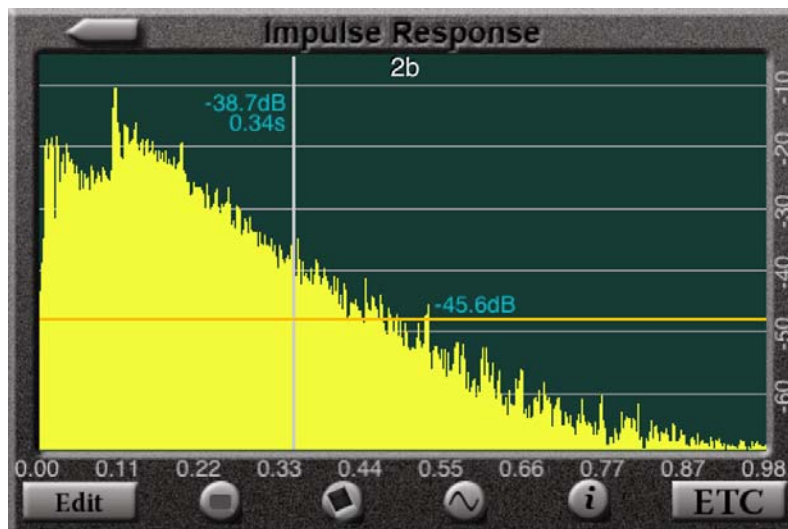

Figure 4.2: Screen shot captured from the *AudioTools* application showing an ETC plot.

Another function of the *AudioTools* application is the ability to calculate reverberation time. It can do so using two different methods: Reverb EDT (Early Detection Time) and Reverb T30 (RT60). In the previous **Figure 4.2**, one can see that the slope of amplitude vs. time is not constant. There is a steep portion which is closest to the peak amplitude, followed by a shallower portion that approaches zero with time. The former is known as the early reflections, and the latter is the decay portion. The EDT value uses the first part of the decay (0 dB to -5 dB) in order

to extrapolate a slope. Heard here are the more distinct sounds, such as early echoes, which have more variance depending on where one is in relation to the generated noise. The T30 value uses the later part of the decay (-5 dB to -35 dB). Leaving out the sharp early measurements in the decay, this value best represents the diffuse portion of the reverberation, which is independent of room position.

Last year, the engineering interns determined theoretical values of important acoustic characteristics including the room constant and the reverberation time, which use the following equations:

$$R = 0.0929 \left[\frac{Sa}{1-a} \right] \quad (4.1)$$

Where:

R represents the acoustical room constant (m²-Sabine)

Sa represents the total absorption (Sabine)

a represents the average absorption coefficient

Along with R, the theoretical reverberation time was calculated:

$$T = 0.05 \frac{VOL}{Sa} \quad (4.2)$$

Where:

T represents the theoretical reverberation time (s)

VOL represents the total volume of the space (m³)

Another function of the *AudioTools* application is a clarity measurement (C50) also referred to as the direct-to-reverberant ratio. This is the energy ratio of the first 50 milliseconds of the direct sound to the steady state reverberation. It is a standard to evaluate how clearly speech can be heard.

Procedure

On June 21, Nick Dika from iZotope, Inc. arrived on Appledore Island to assist with this assignment. Nick brought an iPhone loaded with the *AudioTools* application. The application has the ability to make a wide variety of measurements from a single, handheld device.

First, the application was used to measure background noise in Kiggin's Commons. This helps quantify ambient noise that is generally heard in the empty room.

The next analysis done was a sweep test. This test can be used to describe the acoustic characteristics of a room. Several 14 second sweep tests were performed to determine reverberation times for the room.

The sweep tests were performed at various combinations of sound generation and recording locations. The positions are shown in **Figure 4.3** on the next page.

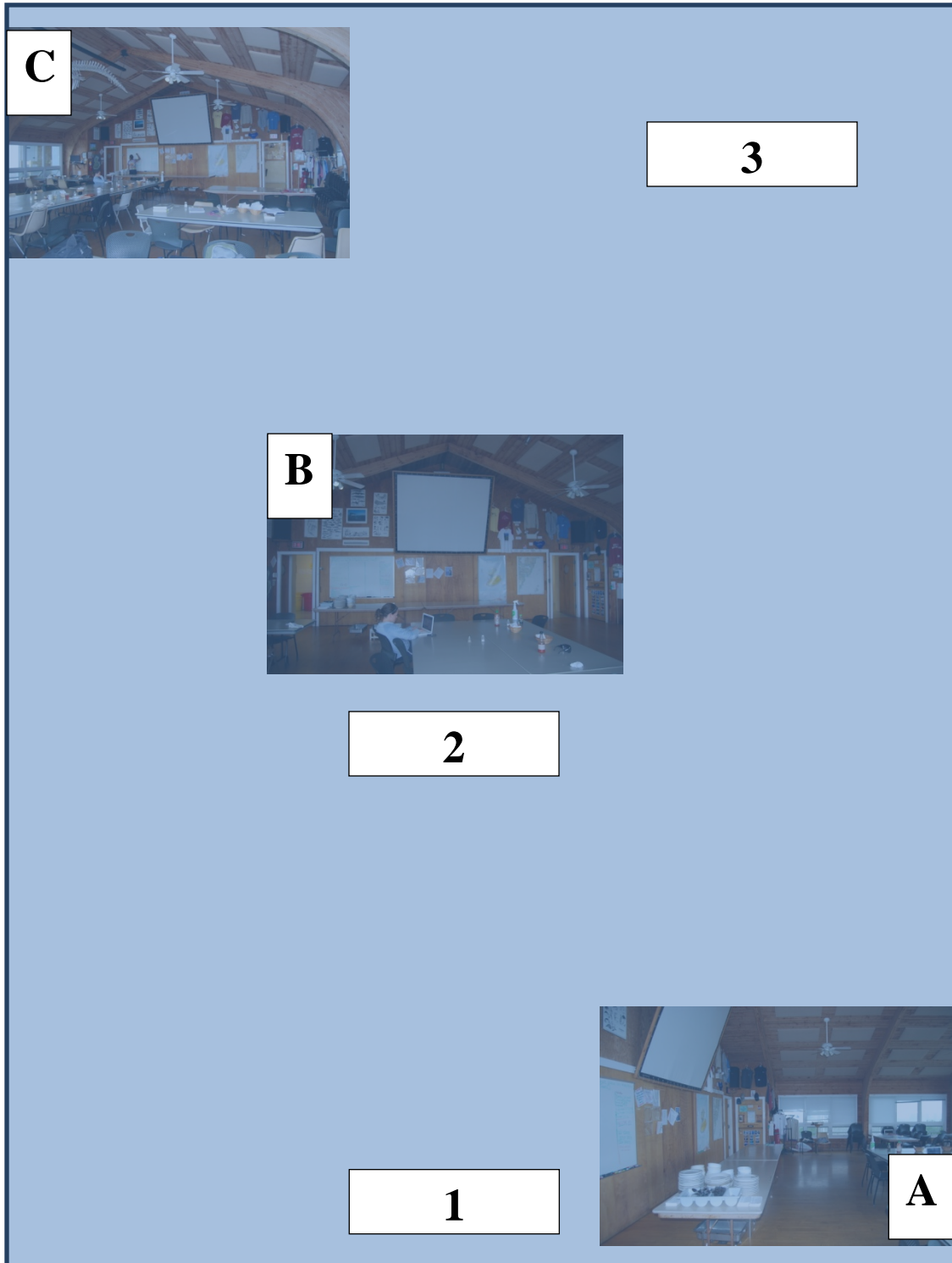

Figure 4.3: A representation of the experimental setup for the sweep testing.

Numerical values indicate sound generation locations and alphabetic values indicate sound recording locations.

Results and Analysis

The background noise in the room was first measured. The following **Table 4.1** shows how the background noise differs from the values that last year's interns measured.

Table 4.7: Background noise in Kiggin's Commons

Octave Band Center Frequency (Hz)	Background Noise-SPL w/o Panels (Db)	Background Noise-SPL w/Panels (Db)	Percent Improvement (%)
250	47	43	8.51
500	45	39.7	11.78
1000	41	38.4	6.34
2000	41	36.8	10.24
4000	37	33.6	9.19
8000	48	32.5	32.29
dBA	53	44.6	15.85

It should be noted that the iPhone microphone has a high pass filter which blocks low frequency sounds (wind, etc.), so signals lower than 125 Hz were thrown out.

The values in **Table 4.1** were generated with no one in the room. The background noise was due to ambient sounds from the kitchen and the outdoors. Though the panels show improvement when the room is relatively quiet, it is more interesting to see their effect when the room is fully occupied.

For this comparison, the room was subjected to a sweep test, which resulted in experimental reverberation times. In order to quantify the improvement in the room, these results were compared with the previous interns' calculated values.

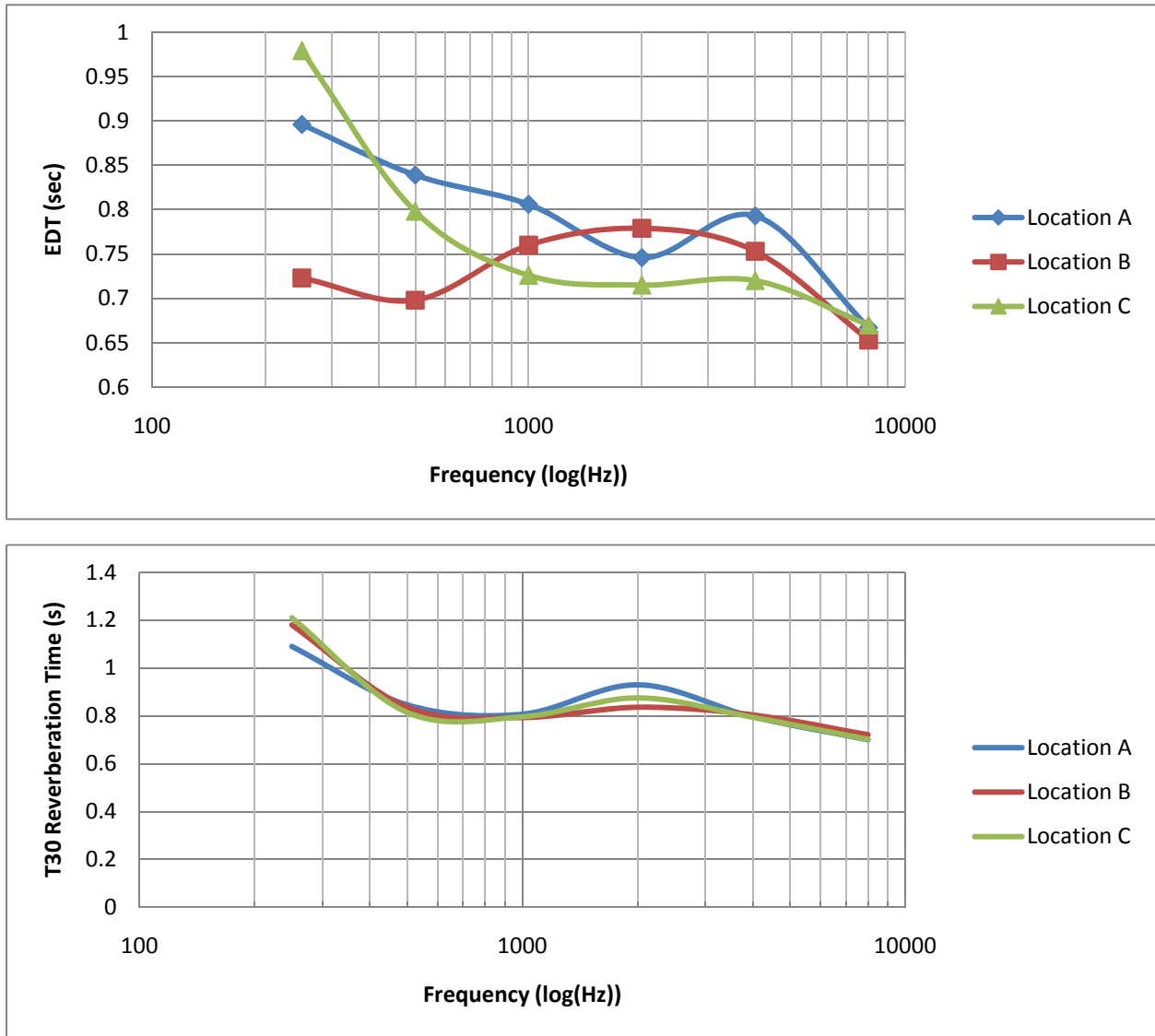

Figure 4.4: Calculated reverberation times from the T30 method and the EDT method shows a dependence of room positioning.

The past interns' reverberation times were based on different assumptions of the room space characteristics, as well as the occupation of the room. Because their method of calculating did not take into account the geometry of the room, the most useful comparison to make is the T30 reverberation time. The following charts help to illustrate that EDT can vary greatly as a function of room position, while the profile of the T30 response to the impulse disturbance is largely unaffected by position. The above data was collected from the *AudioTools* application. The sound was produced in one location while the T30 and EDT measurements were taken at different locations throughout the room, which is why we see different profiles in the EDT graph.

The following **Figure 4.5** shows the results from the sweep testing as compared to the results from the 2010 intern's theoretical values.

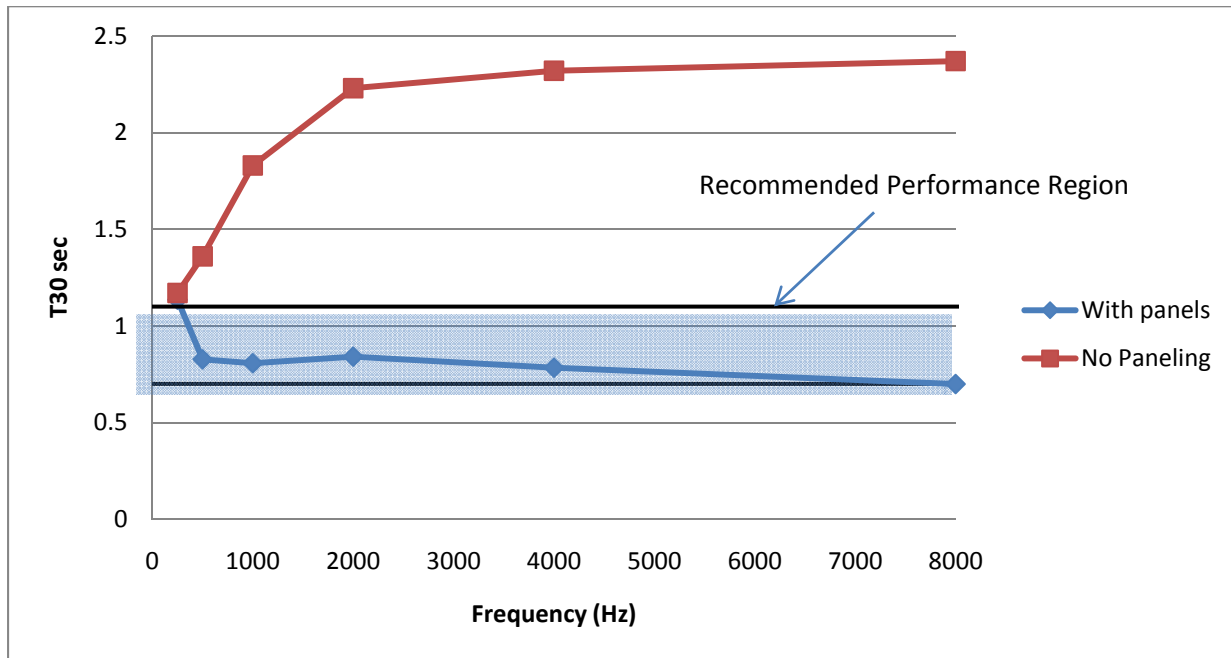

Figure 4.5: The effect that the Acoustic Paneling has on T30 calculated reverberation time as a function of frequency.

The chart shows reverberation time versus frequency for both room conditions. Without paneling, the room has a low reverberation time at low frequencies, but is unable to sustain this performance with increased frequency. The chart illustrates that the addition of the paneling has improved the dining room acoustics. Last year's intern's reported that the recommended reverberation time for this type of room is between 0.7 and 1.1 seconds. This is shown in the shaded region of **Figure 4.5** above.

Acting as a *low-pass filter*, the paneling does a better job absorbing the noise at higher frequencies. This point is further illustrated in **Table 4.2:**

Table 4.2: Percent improvement at varying frequencies

Frequency (Hz)	Percent Difference (%)
250	2.94
500	39.19
1000	55.90
2000	62.29
4000	66.23
8000	70.50

The panel's effect is more pronounced at higher frequencies, which is what we would expect using the T30 calculation.

We must, however, take advantage of the fact that our acoustic analysis used more sophisticated software. The aforementioned EDT can give important acoustic information about the specific space, reflecting the effect of room geometry and location. We can see how one's position in the room affects the quality of sound they will hear by looking at **Figure 4.4** above, which shows the reverberation time at different locations in the room.

Locations A, B, and C represent different places in the room. The sound was generated at position 1 to represent someone giving a lecture. The data suggests that at low frequencies, the listener at position B will hear the speaker more clearly than the other two positions. At mid-range frequencies (1000 – 4000 Hz) the listener at position C hears the speaker most clearly.

The clarity of the room was also looked at. For the same speaker position, the following **Table 4.3** summarizes the C50 measurements where acceptable values are greater than 0 dB.:

Table 4.3 : Clarity measurements

Octave Band	C50 (dB)	
	B	C
250	2.34	-0.32
500	2.74	1.79
1000	3.56	1.95
2000	1.04	1.85
4000	1.34	1.31
8000	2.08	2.66
Averages:	2.18	1.54

Location A was left out of this analysis, as the only sounds hitting the microphone are reflected noise. (See the location of A in the procedure section).

Mealtime background noise was also measured. The results are summarized in **Table 4.4**, at the top of the next page:

Table 4.4: dBA measurements

	Lunch	Dinner		Old Lunch	Old Dinner
position #	SPL (dBA)	SPL(dBA)		SPL (dBA)	SPL(dBA)
1	67.4	62.9		72	68
2	69	67.8		70	72
3	67.1	63.8		72	72
4	62.9	68.2		65	73
5	69.5	67.2		76	72
6	69.1	69.4		70	67

This is a rather difficult test to control. Many factors will go into these numbers, some of which include outside noises such as gulls, wind, the ocean, as well as indoor noises like loud conversations or people walking around. It is important to remember that the decibel represents a logarithmic value. A small decrease in decibels is a few orders of magnitudes quieter.

Recommendations

After a quantitative analysis, in conjunction with the overwhelming qualitative approval, it is recommended that SML take no further action on the acoustical performance of Kiggin's Commons. The observed improvements have put the dining hall well into the acceptable range. It is not worth spending additional money and time on greater improvements.

Trash, Recycling, and Composting Shed for Temporary Storage

Background

The existing sheds which are used to temporarily store garbage and recycling materials are old, run down, and unsightly. While practical, the buildings lack an efficient and pleasing design. The shed's function is to allow the island to dispose of materials on the mainland once a week, as opposed to multiple times. They also store compost material before it is taken to the composting pile.



Figure 7.1: Existing trash, compost, and recycling sheds.

Objective:

Determine the space needs and configuration of a new shed to house trash, recycling matter, and compost. Improve the aesthetic and functional qualities of this storage system.

Procedure:

SML Director Willy Bemis was consulted to obtain a better understanding of the problems with the current shed and what the island would like to see in a new design. He conveyed that the shed was an eye sore, unsanitary, unprofessional looking, and in an undesirable place. The new shed should blend in more with its surroundings and should not be one of the first things that

visitors to SML see. He also stressed that there should be sufficient drainage around the new shed to prevent puddles from forming.

Island staff was interviewed to get more opinions about the current shed and suggestions for a new one. The majority of the staff saw no problems with the current design, but a few mentioned that there could be more space in the recycling and garbage compartments. Another suggestion was to make island composting more efficient by separating the liquids out. Other staff members were concerned about lifting heavy buckets and having to reach the tops of shelves if the shed were made bigger. They stressed that the most important items be kept on the ground.

An area that would not interfere with nearby buildings and systems is desirable for this structure. First explored was the area next to the Water Conservation Building (WCB) on the side facing towards dorm one. However, this location is not suitable since it would restrict access to the wiring and plumbing near the building, complicate further expansion, and also result in drainage problems. It was decided that a better option would be to clear the land near the wood storage area for the new shed, since it would not interfere with current infrastructure and contained sufficient flat space. Additionally, drainage would not be a problem since the roof could be slanted towards the back, allowing water to run off into the low area behind the new structure. This area can be seen below in **Figure 7.1**, below:



Figure 7.2: Location of new shed

To determine the dimensions of the new shed, the existing sheds were measured. Both the outer dimensions as well as the heights of the shelves inside were determined. Additionally, the sizes of the various storage bins used to recycle materials were recorded.

Before deciding on final dimensions, the compartments were laid out using tape measure and string in their anticipated designs, with the various storage bins set up inside them. This layout ensured that the space between shelves was not overly cramped, and that each compartment was easy and comfortable to move around in.

Results and Analysis:

The design for the new shed aimed for greater accessibility and increased ease of use. Thus, it was decided to design a walk-in shed. The shed would have four different compartments: compost, cardboard, recycling, and trash. This fourth compartment was added to store the colored trash bins used for recycling, which currently are an unpleasant view sitting outside the sheds. A walk in shed also prevents the staff from having to reach into the back of compartments and increases storage room. Each compartment, besides for trash, will have shelving to make better use of the height required for a walk in shed. Next, the insides of the compartments were designed to maximize space.

From observations and interviews with kitchen staff regarding the compost compartment, it became clear that the majority of the compost bins currently in the shed are never used, and that this shed is rarely full. Additionally, the full compost bins can be heavy. To address these problems, the compartment was designed with an upper shelf for storage of unused bins, or to be used as over-flow space if the lower shelves happened to be full. However, this would most likely not be a concern since the compost would begin to smell and attract bugs. In this way, the bins on the floor would be used first and there would rarely be a need to lift a full bin to or from the top shelf.

For the cardboard compartment, shelving was again used to provide two layers of storage. However, the shelves were made higher than in the compost compartment to account for the cardboard that often sticks out of the bins. The size of the cardboard compartment was expanded since the work interns mentioned that the current one is often close to full. However, unlike the compost bins, cardboard bins are light, so the extra height of the shelves will not make them troublesome to lift.

The last shelving compartment is for the recycling bins. There are three different colored bins: red for glass, three yellow ones labeled for different types of plastic, and green for metal. Usually in one week, all three types of plastic recycle bins, two metal bins, and one glass bin are filled up. Thus, enough space was allotted to ensure that at least these six bins could be placed on the floor. For extra space, room for seven was designed for the floor, while the extra bins will be placed on the shelves. The shelves were made high enough to ensure adequate space above both levels of bins so that they would not need to be taken out in order to be filled up.

The fourth compartment is for trash. It is still a walk in like the other compartments, and while it was made bigger, there was no need for shelving since the trash bags can be piled on top of each other.

The following design is based on the procedure and results above:



Figure 7.3: Shed Design

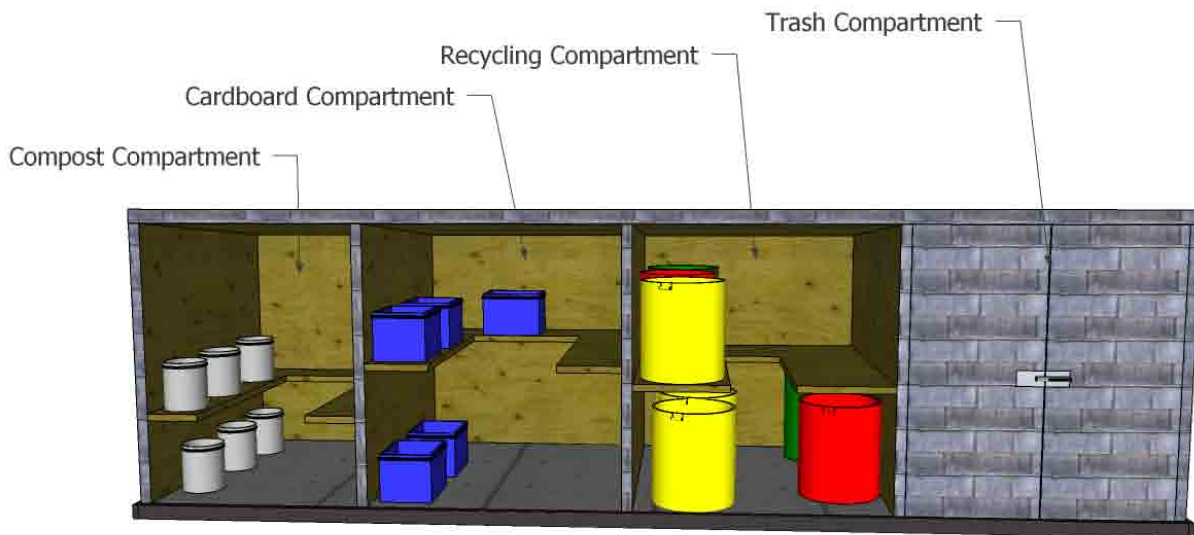

Figure 7.5: Head-on view with compartments labeled

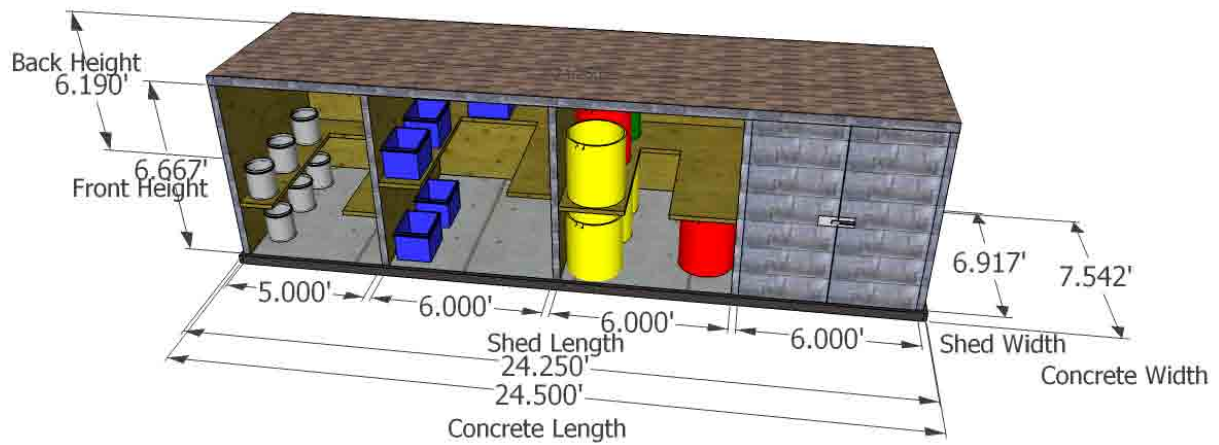

Figure 7.6: Dimensioned drawing of proposed design

Table 8: Comparison of shed dimensions

Compartment	Old						New					
	Length (ft)	Depth (ft)	Front Height (ft)	Back Height (ft)	Floor Area (ft ²)	Volume (ft ³)	Length (ft)	Depth (ft)	Front Height (ft)	Back Height (ft)	Floor Area (ft ²)	Volume (ft ³)
Compost	8.33	4.33	5.29	4.46	36.11	176.04	5.00	6.92	6.67	6.19	34.59	222.33
Cardboard	8.33	4.33	5.29	4.46	36.11	176.04	6.00	6.92	6.67	6.19	41.50	266.80
Recycling				4.46	0.00	0.00	6.00	6.92	6.67	6.19	41.50	266.80
Trash	8.33	4.33	5.29	4.46	36.11	176.04	6.00	6.92	6.67	6.19	41.50	266.80

As shown in the above figures and tables, the overall volume of all compartments was increased to ensure there was adequate space and to allow for expansion. The length of all compartments was decreased since the room was made up for in height and depth. The floor space of the compost compartment was decreased since the shelves will allow for extra storage. However, the floor space of the other shelving compartments was slightly increased so that the shelves could be wide enough to hold the larger recycling and cardboard bins. This was to ensure there was room for walking in between the larger shelves. The sizes of the bins on these shelves can be seen below:

Table 7.2: Bin sizes

Bin Type	Critical Dimensions (ft)	Height (ft)
Compost	1	1.17
Cardboard	1.6	2.25
Recycling	2	2.333

The majority of the shed will be constructed with wood over a concrete base. It is also suggested that a layer of cinder blocks be put in between the concrete and wood to protect the wood from rotting. The outside will be covered in cedar shake siding, the same as the WCB to help it blend in with the surroundings.

The approximate amounts of the major materials needed for construction can be seen below:

Table 7.3: Amounts of materials needed

Material		
Wood	Component	Total Area (ft²)
	Outside panels	88.93
	Inner Dividers	133.40
	Back	150.01
	Composting Shelves - Long	16.60
	Composting Shelves - Short	3.12
	Cardboard Shelves - Long	20.75
	Cardboard Shelves - Short	4.50
	Recycle Shelves - Long	31.13
	Recycle Shelves - Short	3.38
	Doors	160.35
Total Wood		612.17
Roofing		176.22
Cedar Shakes		399.29
Concrete		184.79

Recommendations:

In building a new shed to house temporary trash, recycling, and compost materials, it is suggested that SML use the above design dimensions and layout. It is a more accessible and aesthetically pleasing shed than the current design and will be a great addition to the island.

It is also recommended that the island considers separating liquids out of the compost. Phil Thompson expressed concern that there was too much liquid waste in the compost system. Ideally, the island would have compost for solids and a separate system for liquids. Joe Ducharme of Clivus Multrum helped design a liquid composting bio-filter which uses the process of vermiculture. The design would be similar to that shown below:

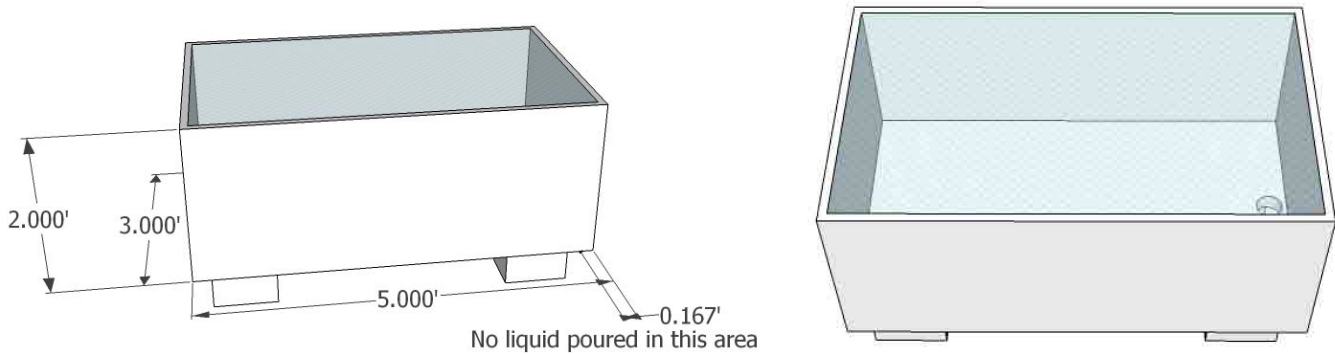

Figure 7.6: Proposed liquid compost design

The box would be 5 feet long, 3 feet deep, 2feet tall, and be made of plywood and cinder blocks. The wood from the current trash shed could be recycled and used for this system. The bottom would be sloped down at 2-3° so that liquids flow toward the front of the box. In the front there would be an 18 inch area near the drain that does not have liquid added to it. The box will contain an even mixture of peat moss and planar shavings to absorb moisture. To begin the compost process, food scraps such as lettuce, coffee grinds, and potato peels should be used and then worms would be added to the system. Joe Ducharme of Clivus offered to donate worms if the project is implemented.

To maintain the system, liquid compost is poured in a different half of the bin every other day. An additional thin layer of the peat moss and planar shavings should be added occasionally to avoid bug and larvae growth. There should also be a hinged screen on the top of the box to keep animals out. The system would be covered to prevent extra moisture from entering. The box could be placed on the side of the water conservation building under the overhang and close to the kitchen. A solar powered fan should also be installed to pull oxygen in and let the heat escape. Due to the box's tilt, nutrient rich liquid will exit the compost from the front and can be collected and used as fertilizer. During the off season, if soil or straw are piled around the compost box to insulate it and if there is a significant amount of food scraps added, the worms will likely survive until the next season.

Acknowledgements

A very warm thank you to the following people for their help in making these projects happen:

Ross Hansen

Doug Gerry

Mike Rosen

Nick Dika

Dan Broman

Nancy Kinner

Mike Dalton

Kevan Carpenter

Tom Johnson

Zach Robinson

Justin Eisfeller

Kevin Wells

Robin Collins

Val Anderson

Joe Ducharme

Kevin Jerram

Willy Bemis

SML Kitchen Staff

Hal Weeks

SML Work Interns

Future Project Suggestions

Green Grid Expansion

Currently, the renewable energy sources on Appledore Island generate more electricity than can be used by the grid. The surplus electricity is sent through resistive heaters which convert the electrical energy to thermal energy, which is then dissipated in the Radar Tower. The next step is to connect the Kingsbury House to this energy source. As new solar arrays are introduced to the system, more loads will need to be added to meet this generation. This constant balancing act will need to be well thought out so that there is no situation where generated electricity is wasted. A possible project could be to understand the load profiles of various buildings around campus in order to understand the correct order of hooking buildings up to the Green Grid.

Data Acquisition

A big shortcoming in looking at the current renewable energy sources on Appledore Island (solar arrays, wind turbine) is the lack of real-time data that is easily accessible to SML staff. Interns should seek to understand the Data Acquisition system on the island in order to understand how to make it functional and useful. Once this data is acquired, a more accurate understanding of the renewable energy systems can be obtained.

Start-Up Current Analysis

It was determined that one of the largest contributors to the power outages on Appledore Island are related to the high current demanded by various motors around the island upon start-up. This current can be up to 10 times higher than normal operating conditions. Interns should identify the significant start-up current demand on the island, and suggest methods for reducing the risk of a generator shut-down. Soft starting the machinery or placing capacitors in parallel with the machinery which kick on only at start-up may be a few things to look at.

Slow Sand Filter Design

A particular sand was found to be an effective solution for reducing turbidity and *E. Coli*. Perhaps a larger question is how this sand filter can be implemented on the island scale. Interns should decide what the most appropriate system level design is for Appledore Island. Design factors include what to do with the ripening water, whether or not to incorporate a holding tank, and what is the best orientation for a distribution array.